

# Maxon Premixing Equipment

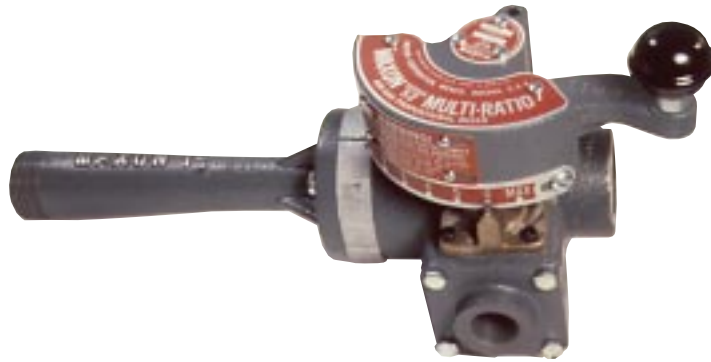

**MULTI-RATIO™ Mixers**

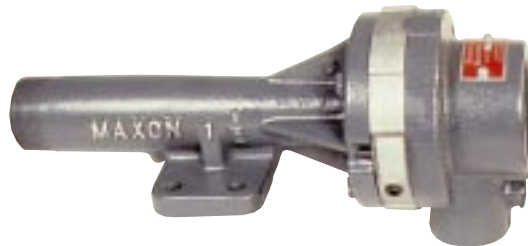

**Series "LG" Mixing Tubes**



**Series "HG" Mixing Tubes**

- **Air/gas mixing devices** for use with all Maxon premix burner systems to provide thorough blending of air/gas mixture
- **Uses most clean fuel gases**
- **May be used with single** or multiple burner systems
- **Series "LG" Mixing Tubes and MULTI-RATIO™ Mixers** are designed for use with low pressure gas
- **Series "HG" Mixing Tubes** use kinetic energy of higher gas pressures to thoroughly blend the air/gas mixture

## Premix Burner Systems



**Maxon-P/S Radiant Burners**



**STICKTITE™ Nozzles**

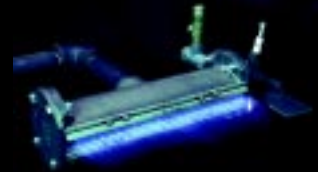

**Style A & B  
LINOFLAME® Burners**

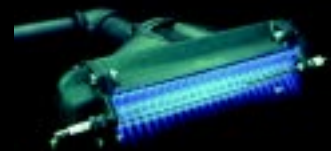

**VFL & VFH  
LINOFLAME® Burners**

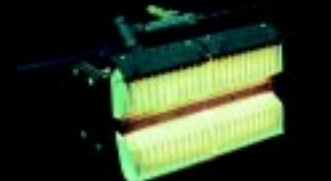

**INFRAWAVE® Burners**



## MULTI-RATIO™ Mixers

Maxon MULTI-RATIO™ Mixers are air/fuel proportioning devices designed for use with all Maxon premix burner systems, including both single and multiple burner systems.

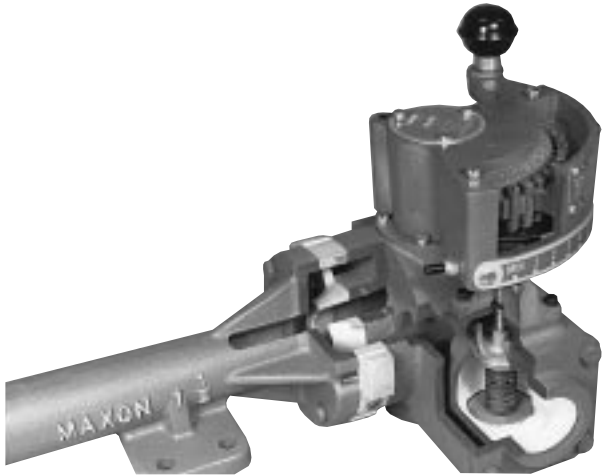

MULTI-RATIO™ Mixer

They provide air/gas ratio control throughout the firing range by incorporating an “LG” Mixing Tube and adjustable gradient air/fuel control valve in one compact unit.

MULTI-RATIO™ Mixers are suited for use with most clean, low pressure gases. Combustion air at 6 to 16 psi is used to entrain the low pressure gas.

Built-in adjusting screws permit tailoring burner performance to your specific needs. Single point control simplifies adjustment.

### **Principle of Operation**

Characterized air port and gas valve disc are carefully matched to achieve desired heat release using most clean gases of 500 to 3200 Btu/ft<sup>3</sup> heating value.

The unit delivers air/fuel mixture to premix burners at mixture pressures as high as 13" wc when using a 16 oz. pressure blower.

The MULTI-RATIO™ Mixer's capacity can be modified in the field by replacing compatible air orifice plates.

## Series “LG” Mixing Tubes

Series “LG” Mixing Tubes provide thorough blending of the air/gas mixture for all Maxon premix burner systems.

Most clean, low pressure gases may be used. When combined with a combustion air blower and Maxon MICRO-RATIO® control valve, the “LG” Mixing Tube can offer localized mixing of pre-proportioned air and fuel to single or multiple burner systems.

A wide range of capacities provides application flexibility.

### **Principle of Operation**

Combustion air at 6-16 psi from a pressure blower is forced through an air orifice plate, drawing fuel gas into a mixing tube throat. Capacity is determined by fuel characteristics, air pressure and air orifice plate size.

Most clean fuel gases of 500-3200 Btu/ft<sup>3</sup> can be used at supply pressures of 3" wc to 8 psi at the inlet of the proportioning device.

Balancing among multiple mixing tubes is accomplished with a built-in gas shading disc.

Capacity can be modified in the field by replacing compatible air orifice plates.



Series “LG” Mixing Tube

## Series “HG” Mixing Tubes

Using the kinetic energy of higher gas pressures, the Series “HG” Mixing Tube provides a thoroughly blended air/gas mixture.

The higher gas pressure allows use of a lower pressure combustion air blower. In combination with a Maxon MICRO-RATIO® control valve and combustion air blower, the “HG” Mixing Tube can provide localized mixing of air and fuel to single or multiple burner systems.

Adjustment is simple through single point proportioning.

Like the MULTI-RATIO™ Mixers and Series “LG” Tubes, they can be used with all Maxon premix burner systems.

In addition, Series “HG” Mixing Tubes can be sized for partial premixing of air/gas ratios to Maxon AIRFLO® burner systems, including:

**COMBUSTIFUME®**

**LO-NOX®**

**“66” AIRFLO®**

**“LV” AIRFLO®**

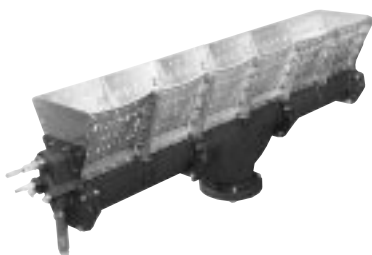

Series “HG” Mixing Tube

### **Principle of Operation**

Series “HG” Mixing Tubes distribute fuel gas through a chamber surrounding the combustion air stream. Multiple gas ports (drilled for the specific gas type and combustion air pressure used) allow the higher pressure gas to be injected into the lower pressure combustion air stream.

This means very low combustion air pressure drops. As little as 6 ounces air differential at the mixing tube inlet can produce as much as 10" wc mixture pressure at the mixing tube outlet.

Compared to the 14 ounce differential required to achieve similar performance using typical low gas pressure mixing systems, substantial savings are possible in both initial and operating costs.

Gas must be supplied at pressures of 2 PSIG or higher. Each gas orifice is field-accessible through an external plugged hole which may also be used as a gas pressure test connection.

**Maxon catalog bulletin 7000 describes MICRO-RATIO® control valves which throttle air and gas volumes to the Series “LG” Mixing Tube and Series “HG” Mixing Tube**



## Typical Applications

The following illustrations show Maxon MULTI-RATIO™ Mixers and Series “LG” or “HG” Mixing Tubes used in typical furnace applications. Both systems include a central combustion air supply and multiple Sealed Nozzle Burners. This arrangement would be similar for installations using other Maxon premix burners.

One mixing device may be used to feed single or multiple burner elements, or separate mixers may be used for each unit or zone of a multi-stage system.

A complete burner system will also include burner, gas train, pressure blower and control panel. In addition, an “LG” or “HG” Mixing Tube system will require an air/gas control valve, such as the Maxon MICRO-RATIO® Valve shown below.

### MULTI-RATIO™ Mixers

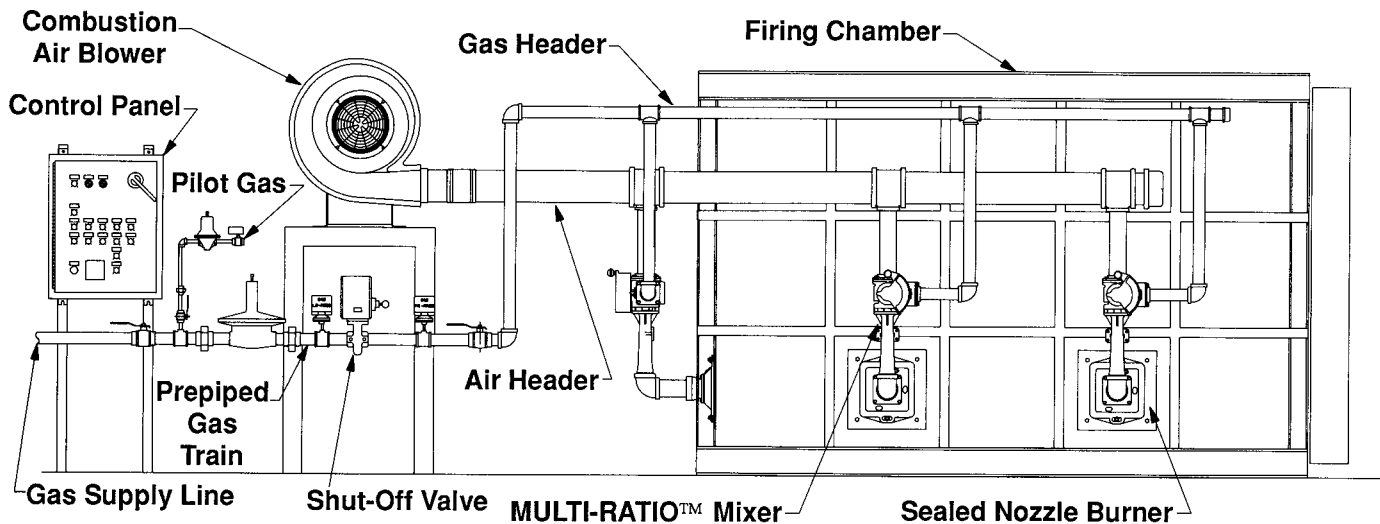

### Series “LG” or “HG” Mixing Tubes (with Maxon MICRO-RATIO® Valve)

