

Maxon Model “400” OVENPAK® Gas Burners



Model 415 OVENPAK® Burner
with connecting base and linkage
assembly to adapt customer's automatic
electric control motor

- Burns any clean fuel gas
- Fires into passing air streams
- Requires only low pressure gas
- Provides clean combustion with low NOx levels
- Compact burner design provides quick and easy installation
- Simple field adjustment and maintenance

Model “400” OVENPAK® Burner applications have included:

Air heating in ovens and dryers, paint finishing lines, paper and textile machines, food baking ovens, coffee roasters, grain dryers, and fume incinerators. Manufactured under U.S. patent #3,574,508; Canadian and European patents granted and pending.



Maxon Model "400" OVENPAK® Gas Burners



Model EB-3 OVENPAK® Burner with connecting base and linkage assembly

Provide application flexibility with:

- 40:1 turndown or more
- Over 90 different styles and sizes
- Heat releases to 16,500,000 Btu/hr
- Cost-effective external blower (EB) version

Typical piping layout with "Block and Bleed" gas train arrangement

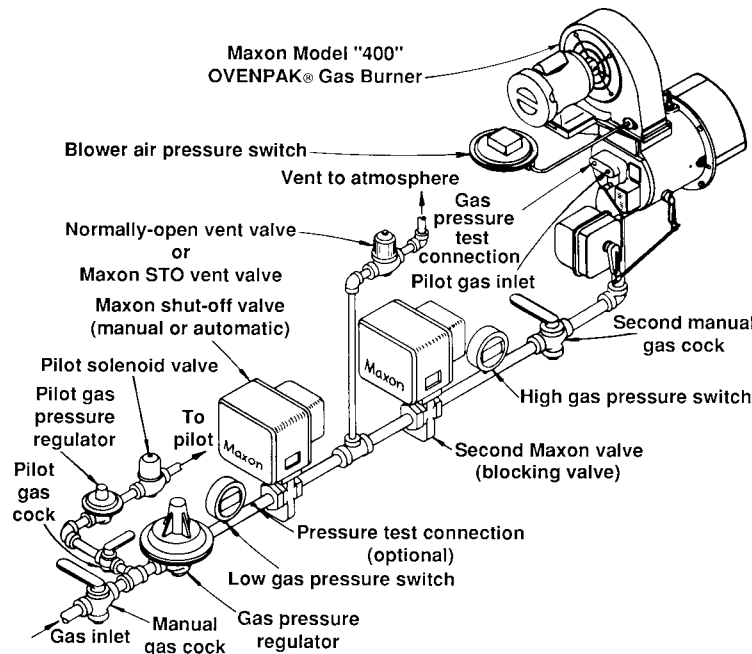

Maxon Pre-Assembled Package Model “400” OVENPAK® Gas Burner System



Model 435
OVENPAK®
Burner with pre-
assembled “Block
& Bleed” pipe
train and pre-
wired into
package system

- A complete “packaged burner” system for maximum efficiency
- Pre-assembled system includes:
 - High turndown Model “400” OVENPAK® Burner
 - Completely assembled and pre-wired pipe train package
- Fast and easy installation with your choice of mounting options:
 - Arranged for mounting onto your existing duct;
 - Or mounted by Maxon in a pre-fabricated combustion heater/duct

Maxon Packaged Heater/Duct Sections for Pre-Assembled OVENPAK® Gas Burner Systems

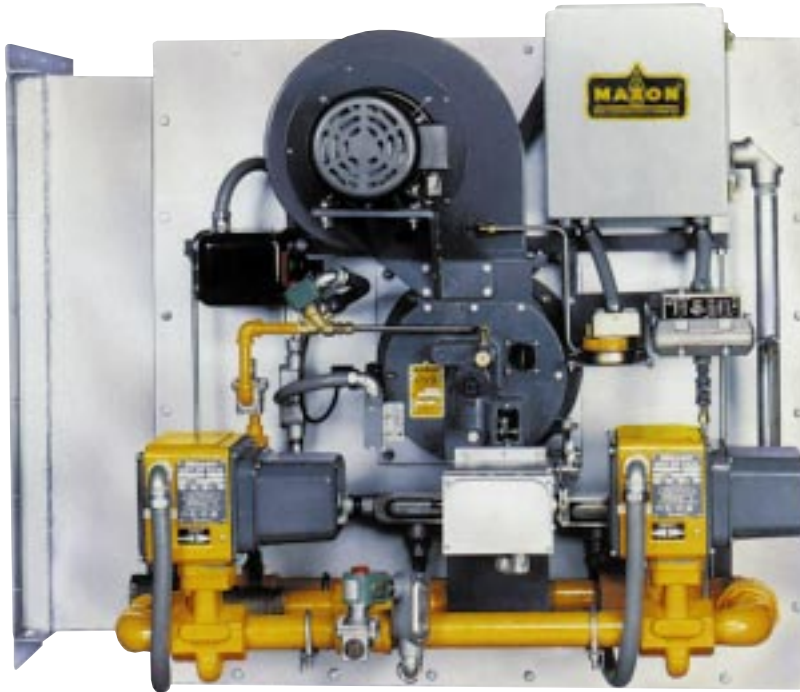

Model 425
OVENPAK® Burner
pre-assembled
package system,
installed and mounted
onto a Maxon pre-
fabricated heater/duct
section

- Reduce your fabrication time and costly design details
- Easy mounting provided by flanged duct connection joints
- Application flexibility offered by:
 - Three duct sizes
 - Five capacity options
 - Optional return/inlet duct opening positions
- Discharge air volumes up to 12,000 SCFM
- Handles discharge air temperatures up to 600°F (316°C)

