



Kotron® Model 805 Smart RF Level Transmitter

DESCRIPTION

The Kotron 805 Smart Transmitter is a loop-powered, 24 VDC, liquid-level transmitter based on proven RF Capacitance technology. Encompassing a number of significant engineering accomplishments, this high performance RF level transmitter is designed to provide reliable measurement performance well beyond that of competitive units.

The innovative dual compartment enclosure is a first in the industry, orienting the wiring and electronics in the same plane, and angled to maximize ease of installation, set-up and data display.

TECHNOLOGY

The Kotron 805 combines the proven technology of RF Capacitance with advanced signal processing techniques and convenient user features. As level rises and falls in a tank or vessel, the amount of capacitance developed between the sensing probe and the tank wall (or ground) also rises and falls. This change in capacitance is digitized for display and HART® communications (optional) and converted into a proportional 4–20 mA analog output signal.

APPLICATIONS

MEDIA: Liquids or slurries; hydrocarbons to water-based media (dielectric 1.5–100).

VESSELS: Most process or storage vessels up to rated probe temperature and pressure.

CONDITIONS: All level measurement and control applications including process conditions exhibiting visible vapors, surface agitation, bubbling, high fill/empty rates and low product level.



FEATURES

- Accepted, proven RF capacitance technology
- Two-wire, 24 VDC, loop-powered level transmitter
- HART digital communications (optional)
- Innovative, ergonomic housing
- Two-line, 8-character LCD w/keypad (optional)
- Probe designs to +1000° F (+535° C)/5000 psig (345 bar)
- Intrinsically safe and Non-Incendive approvals
- Probes available from 6 inches to 150 feet (15 to 4570 centimeters)

KOTRON MODEL 805

SMART RF LEVEL TRANSMITTER



Kotron Model 805 Smart Level Transmitter shown with Magneseal® Sensing Probe.

- **Low Power, High Performance**

Kotron 805 operates on a remarkably low amount of current. A microprocessor controls the measurement engine, drives the liquid crystal display, enables keypad operation, controls HART communications and provides a 4–20 mA output.

A separate wiring compartment isolates the power/signal conductors from the electronics compartment via a sealed feed-through. The compartment is designed to maximize ease of wiring and includes surge and transient protection.

The unique enclosure is conveniently angled at 45° to facilitate ease of set up and configuration, and to maximize readability of the liquid crystal display.

- **Easy Operation**

The Kotron 805 employs the latest RF Capacitance measurement techniques. The LCD version with two-line display provides a software menu which is very user-friendly featuring push-button calibration, diagnostics, and troubleshooting. HART communication provides the ultimate for calibration, configuration, and diagnostics.

- **Powerful Self Diagnostics**

The 805 offers enhanced self diagnostics previously only found on more powerful line powered instruments. Self diagnostics specifically include continuous check of the electronics plus probe. Error codes and measurement of nominal capacitance (LCD version) assist in calibration and troubleshooting.

- **Simple Calibration**

All capacitance based transmitters require calibration for fluid, probe type, and tank geometry. The 805 offers ease of calibration requiring minimum level change and ease in setting the calibration points.

TRANSMITTER SPECIFICATIONS

FUNCTIONAL/PHYSICAL

Measured Variable:	Liquid Level
Signal Output:	4–20 mA or 4–20 mA with HART (optional)
	3.8 to 20.5 mA useable (meets NAMUR NE 43)
Zero and Range:	0 to 1800 inches (0 to 4570 centimeters)
Span:	5 pF minimum, 10,000 pF maximum
Resolution:	Analog: 0.01 mA
	Display: 0.1 inch
Loop Resistance:	General Purpose/Intrinsically Safe: 650 Ω @ 24 VDC
Damping:	Adjustable 1–45 seconds
Diagnostic Alarm: ①	Adjustable 3.6 mA, 22 mA, HOLD
User Interface: ②	3-button keypad and/or HART communicator
Display:	2-line x 8-character LCD
Power (at terminals):	General Purpose: 11 to 36 VDC
	Intrinsically Safe: 11 to 28.6 VDC
Menu Language (LCD only):	English, Spanish, French or German
Housing Material:	Aluminum A356T6 (< 0.2% copper)
Net and Gross Weight:	6 lbs. net; 7 lbs. gross
Overall Dimensions (H x W x D):	8.43" x 4.38" x 7.40" (214 x 111 x 188 millimeters)

① 3.6 mA diagnostic alarm only valid without HART option.

② HART communicator Magnetrol P/N 89-5213-XXX sold separately.

PERFORMANCE

Reference Conditions:	+20° C (+68° F)
Linearity:	$\pm 0.25\%$ of span
Accuracy:	$\pm 0.50\%$ of span or 0.1 inch (whichever is greater)
Resolution:	0.1 pF
Repeatability:	$\pm 0.1\%$ of span
Hysteresis:	$\pm 0.1\%$ of span
Response Time:	< 1 second (adjustable via damping)
Operating Temperature Range:	-40° to +175° F (-40° to +80° C)
LCD Temperature Range:	-5° to +160° F (-20° to +70° C)
Operating Temperature Effect:	Approximately $\pm 0.03\%$ per °C
Humidity:	0–99%, non-condensing



PROBE SPECIFICATIONS

A complete line of rigid and flexible probes are available for the Kotron 805 Transmitter.

Types of probes to choose from include:

- Rigid insulated rod probes in Teflon® (TFE), Halar® (ECTFE), and Kynar® (PVDF)
- Rigid bare probes in 316 stainless steel and Hastelloy C
- Rigid all plastic probes in Halar (ECTFE) and Kynar (PVDF)
- Bent, ground wire, and inactive sheath probes in many of the above materials
- Stilling well probes
- Sanitary probes
- Reference rod probes
- Flexible probes

AGENCY APPROVALS

AGENCY	MODEL APPROVED	APPROVAL CATEGORY	APPROVAL CLASSES
	805-5XXX-11X	Intrinsically Safe	Class I, Div. 1; Groups A, B, C, & D Class II, Div. 1; Groups E, F, & G Class III T4 Ta = +71° C Entity NEMA 4X IP66
	805-5XXX-11X	Non-Incendive	Class I, Div. 2; Groups A, B, C, & D Class II, Div. 2; Groups F & G Class III T4 Ta = +71° C NEMA 4X IP66
	805-5XXX-110	Intrinsically Safe	Class I, Div. 1; Groups A, B, C, & D Class II, Div. 1; Group E, F, & G (insulated probes) (Group G only with bare probe) Class III T4 Ta = +71° C Entity Type 4X
	805-5XXX-110	Suitable for:	Class I, Div. 2; Groups A, B, C, & D Class II, Div. 2; Groups E, F, & G (insulated probes) (Group G only with bare probe) Class III T4 Ta = +71° C Type 4X
	805-5XXX-A1X	Intrinsically Safe	Ⓔ II 1G EEx ia IIC T6 (-40° to +40° C ambient temp.) Ⓔ II 1G EEx ia IIC T4 (-40° to +80° C ambient temp.)

 These units have been tested to EN 50081-2 and EN 50082-2 and are in compliance with the EMC Directive 89/336/EEC.

DIMENSIONS

INCHES (MM)

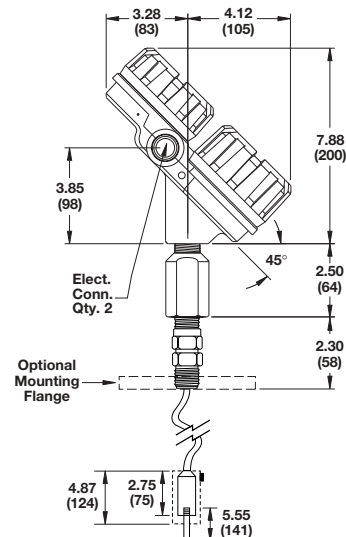
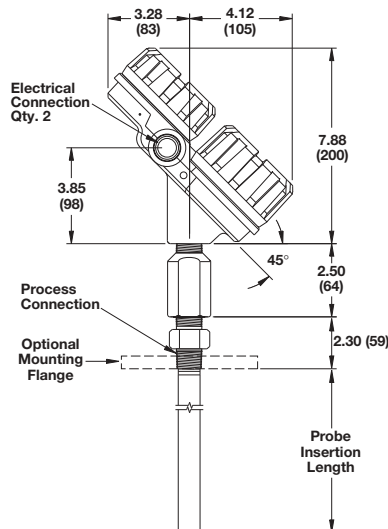
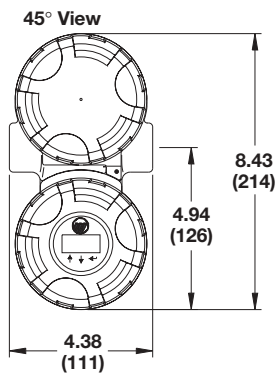

QUALITY



The quality assurance system in place at Magnetrol guarantees the highest level of quality throughout the company. Magnetrol is committed to providing full customer satisfaction both in quality products and quality service.

Magnetrol's quality assurance system is registered to ISO 9001 affirming its commitment to known international quality standards providing the strongest assurance of product/service quality available.

ESP

Expedite Ship Plan

Kotron Smart RF Model 805 Transmitters are available for quick shipment, usually within one week after factory receipt of a purchase order, through the Expedite Ship Plan (ESP). Models covered by ESP service are conveniently color coded in the selection data charts.

To take advantage of ESP, simply match the color coded model number codes (standard dimensions apply).

ESP service may not apply to orders of ten units or more. Contact your local representative for lead times on larger volume orders, as well as other products and options.

WARRANTY



All Magnetrol electronic level and flow controls are warranted free of defects in materials or workmanship for one full year from the date of original factory shipment.

If returned within the warranty period; and, upon factory inspection of the control, the cause of the claim is determined to be covered under the warranty; then, Magnetrol will repair or replace the control at no cost

to the purchaser (or owner) other than transportation.

Magnetrol shall not be liable for misapplication, labor claims, direct or consequential damage or expense arising from the installation or use of equipment. There are no other warranties expressed or implied, except special written warranties covering some Magnetrol products.

For additional information, see Instruction Manual 50-660.



5300 Belmont Road • Downers Grove, Illinois 60515-4499 • 630-969-4000 • Fax 630-969-9489 • www.magnetrol.com
145 Jardin Drive, Units 1 & 2 • Concord, Ontario Canada L4K 1X7 • 905-738-9600 • Fax 905-738-1306
Heikenstraat 6 • B 9240 Zele, Belgium • 052 45.11.11 • Telex 25944 • Fax 052 45.09.93
Regent Business Ctr., Jubilee Rd. • Burgess Hill, Sussex RH15 9TL U.K. • 01444-871313 • Fax 01444-871317

Copyright © 2004 Magnetrol International, Incorporated. All rights reserved. Printed in the USA.
Magnetrol and Magnetrol logotype are registered trademarks of Magnetrol International.

Performance specifications are effective with date of issue and are subject to change without notice.
The brand and product names contained within this document are trademarks or registered trademarks of their respective holders.

BULLETIN: 50-160.3
EFFECTIVE: January 2004
SUPERSEDES: January 2003