



ASSURED QUALITY &
SERVICE COST LESS
ISO 9001

SERIES 75 Liquid float level switches

Magnetrol's series 75 liquid level switches are designed and constructed to provide reliable service. An industry standard in petroleum refineries and chemical plants, thousands of these switches are in daily service throughout the world.

FEATURES

- * Choice of carbon or stainless steel welded float chamber.
- * Stainless steel float and trim.
- * Service pressures up to 138 bar (2000 PSIG).
- * Process temperatures up to 400°C (750°F).
- * Specific gravity ratings down to 0.35.
- * Operating level differentials, fully field adjustable.
- * Single or multiple switch mechanisms available.
- * *Choice of switch mechanisms:*
 - mercury
 - high temperature mercury
 - dry contact
 - hermetically sealed
 - pneumatic.
- * *Choice of switch mechanism enclosures:*
 - CENELEC (EEx d)
 - BASEEFA (Ex d)
 - NEMA 3R for pneumatics
 - NEMA 4X (IP 65), moisture proof.
 - NEMA 7/9 (CSA/FM), explosion proof
 - NEMA 4X/7/9 (CSA.FM), Class I, Div. 1, Group B.
- * *Tank connections and combinations of:*
 - 1" - 1 1/2" - 2"
 - NW 25 - NW 40 - NW 50 (DIN)
 - NPT/socket weld
 - Side/side flanged
 - Side/bottom flanged

APPLICATIONS

- Accumulators
- Receivers
- Flare pots
- Flash tanks
- Scrubbers
- Knock out drums
- Separators
- Storage tanks

Liquid level switches –
have more than 50 years reliability



AGENCY APPROVALS

Agency	Approval ①
CENELEC	EEx d IIC T6, explosion proof EEx ia IIC T6, intrinsically safe②
BASEEFA	Ex d IIC T6
CSA ①	Non-Hazardous CSA Type 4X
	Class I, Div. 2, Groups B, C & D
	Class I, Div. 1, Groups C & D Class II, Div. 1, Groups E, F & G
	Class I, Div. 1, Groups B, C & D Class II, Div. 1, Groups E, F & G
FM ①	Non-Hazardous NEMA 4X
	Class I, Div. 1, Groups C & D Class II, Div. 1, Groups E, F & G
	Class I, Div. 1, Groups B, C & D, Class II, Div. 1, Groups E, F & G
SAA ①	Ex d IIC T6 (IP65)

① Not available with all switches; Consult factory for proper model numbers.

② Consult factory for proper model numbers.

AVAILABLE SWITCH MECHANISMS AND APPLICATION DATA

Series 75 switches are available with several different switch mechanisms – each designed for specific service conditions. Brief descriptions of the individual switch mechanisms and their application are given below.

For electrical ratings, see bulletin BE 42-120.

Mercury switches – Series A & E

Mercury switches offer the advantage of quick visual inspection of contact conditions.

Series A switches are heavy duty units with high load carrying capability.

Series E switches are specifically designed to provide greater vibration resistance.



High temperature mercury switches – Series 2 & 3

Available with all the features of the standard series of mercury switches. Series 2 and 3 feature nickel/copper bare wire and ceramic beaded insulation to allow use in applications where the process temperature does not exceed 400°C (750°F).

Series 2 switches correspond to series E switches.

Series 3 switches correspond to series A switches.



Dry contact switches – Series B, C, D & U

These switches are specified in applications where mercury must be avoided – such as in nuclear power plant installations.

Series B and **C** switches are general purpose units with electrical ratings dependent upon maximum liquid temperature.

Series D switches are designed for high DC current applications.

Series U have gold alloy contacts.



Hermetically sealed switches – Series F, HS, W & X

Hermetically sealed switches are for use in special applications where hermetically sealed contacts are required.

The **Series F** switch is well suited for use in applications where the process temperature does not exceed 400°C (750°F).

The **Series HS** switch features a positively pressurized capsule for the entire switch mechanism including contacts. It is suited for use in applications where the process temperature does not exceed 290°C (550°F). It is available with easy access terminals. These switches are ideal where salt and other corrosive atmospheres are found.

Series W have silverplated and **Series X** have goldplated contacts; both suitable for liquid temperatures up to 230°C (450°F).

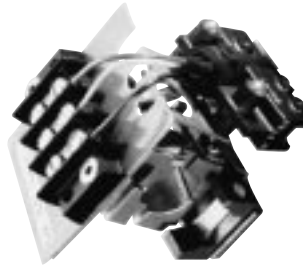

Pneumatic Switches – Series J & K

Pneumatic switches are employed in process industry applications where electrical power is not available or to satisfy safety requirements.

The **Series J** bleed-type switch is intended for general purpose applications.

Series K units are specially designed to provide non-bleed operation with a high degree of vibration resistance.



AVAILABLE SWITCH ENCLOSURES

Electric switches – non hazardous area = **IP 65/NEMA 4X** weather resistant.
Electric switches – hazardous area = **CENELEC/BASEEFA (IP 66)/NEMA 7/9 (IP 65)** explosion proof.
Pneumatic switches = **NEMA 3R (IP 53)** weather resistant.
Consult the factory for drain/heater options.
All housings are standard available with anti corrosive coating.



IP 65 NEMA 4X enclosure



NEMA 7/9 enclosure



BASEEFA enclosure



CENELEC enclosure

PRINCIPLE OF OPERATION

A permanent magnet ① is attached to a pivoted switch actuator ②. As the float/ displacer ③ rises following the liquid level, it raises the attraction sleeve ④ into the field of the magnet, which then snaps against the non-magnetic enclosing tube ⑤, actuating the switch. The enclosing tube provides a static pressure boundary between the switch mechanism and the process. On a falling level, an inconel spring retracts the magnet, deactivating the switch.

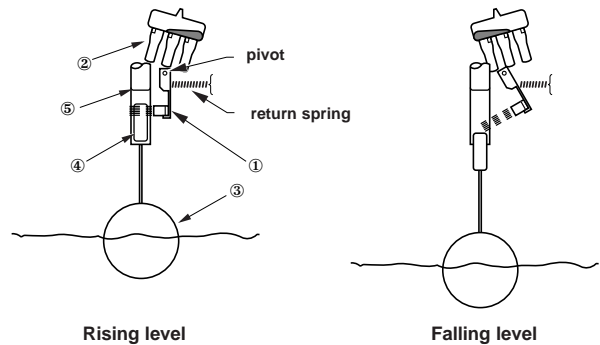

SPECIAL PRODUCT OPTIONS

Series 75 switches are available with a broad range of special options and customer engineered features to meet specific applications conditions, including the following.

- Interface calibration
- Customised installations dimensions
- Special actuation levels
- Code compliance construction
- Special tank connections
- Extreme temperature modifications
- Class 1, Group B explosion proof electrical enclosure
- Special exterior surface preparation and finish

EXPEDITE SHIP PLAN (ESP)

Magnetrol has implemented a quick delivery programme 'ESP', for the most popular units and options. The colour coded selections represent those that benefit from the shortest lead times.

SELECTION DATA

A complete series 75 liquid level switch, consists of 1 order code:

MODEL NUMBER – SPECIFIC GRAVITY & PRESSURE RATINGS — CARBON STEEL CHAMBERS ①

Code	Min. specific gravity Models with material construction code		Pressure rating ③					
	1	2	bar @ °C			PSIG @ °F		
			40° C	230° C	400° C	100° F	450° F	750° F
A	0.60	0.65	42,7	29,0	25,2	620	420	365
B	0.75	0.75	69,0	58,6	51,7	1000	850	750
C	0.60	0.60	34,5	25,5	20,7	500	370	300
G	0.55	0.57	51,7	38,6	32,7	750	560	475
J	0.50	0.53	27,6	20,3	17,2	400	295	250

MODEL NUMBER – SPECIFIC GRAVITY & PRESSURE RATINGS — STAINLESS STEEL CHAMBERS ②

Code	Min. specific gravity Models with material construction code 4	Pressure rating ③					
		bar @ °C			PSIG @ °F		
		40° C	230° C	400° C	100° F	450° F	750° F
A	0.65	42,7	29,0	25,2	620	420	365
B	0.75	69,0	58,6	51,7	1000	850	750
C	0.60	34,5	22,4	19,6	500	325	285
G	0.57	51,7	38,6	32,7	750	560	475
P	0.75	27,6	17,9	15,5	400	260	225
O	0.85	27,6	22,4	19,6	400	325	285

MATERIALS OF CONSTRUCTION

	Chamber	Float	Sleeve
1	Carbon steel ①	316 SS	400 SS
2	Carbon steel ①	316 SS	316 SS
4	316 SS ②	316 SS	316 SS

- ① Carbon steel chamber models are used with material of construction codes 1 and 2 only.
- ② Stainless steel chamber models are used with material of construction code 4 only.
- ③ Models are limited to max. temperature rating of selected switch mechanism. See **Switch mechanism charts** on page 5.
- ④ Contact factory for high pressure and high temperature applications.

SIZE AND TYPE OF TANK CONNECTIONS (see configurations on pages 6 & 8)

	CONNECTION SIZE		
	1" size	1 1/2" size	2" size
Threaded	B20	C20	D20
Socket weld	B30	C30	D30

Flange	STYLE & CONNECTION SIZE – ANSI								
	1" size			1 1/2" size			2" size		
	Cage mounting flange ratings – ANSI								
	150	300	600	150	300	600	150	300	600
upper side/bottom	N30	N40	N50	P30	P40	P50	Q30	Q40	Q50
side/side	S30	S40	S50	T30	T40	T50	V30	V40	V50

Flange	STYLE & CONNECTION SIZE – DIN											
	NW 25 (DIN)				NW 40 (DIN)				NW 50 (DIN)			
	Cage mounting flange ratings – DIN											
	ND16 <small>(DIN 2633) Form C (DIN 2526)</small>	ND25 <small>(DIN 2634) Form C (DIN 2526)</small>	ND40 <small>(DIN 2635) Form C (DIN 2526)</small>	ND64 <small>(DIN 2636) Form E (DIN 2526)</small>	ND16 <small>(DIN 2633) Form C (DIN 2526)</small>	ND25 <small>(DIN 2634) Form C (DIN 2526)</small>	ND40 <small>(DIN 2635) Form C (DIN 2526)</small>	ND64 <small>(DIN 2636) Form E (DIN 2526)</small>	ND16 <small>(DIN 2633) Form C (DIN 2526)</small>	ND25 <small>(DIN 2634) Form C (DIN 2526)</small>	ND40 <small>(DIN 2635) Form C (DIN 2526)</small>	ND64 <small>(DIN 2636) Form E (DIN 2526)</small>
upper side/bottom	1FA	1GA	1HA	1JA	2FA	2GA	2HA	2JA	3FA	3GA	3HA	3JA
side/side	1FB	1GB	1HB	1JB	2FB	2GB	2HB	2JB	3FB	3GB	3HB	3JB

SWITCH MECHANISM AND ENCLOSURE
Refer to right page for pneumatic and electric switch mechanisms.



order code for sealed external cage float level switch

SELECT PNEUMATIC SWITCH MECHANISM & ENCLOSURE

Pneumatic switch description	Max. supply pressure bar (PSIG)	Max. liquid temperature °C (°F)	Bleed orifice Ø mm (inches)	Code (NEMA 3R encl.)	
				mat'l. code 1	mat'l. code 2 & 4
Series J bleed type	6.9 bar (100 PSIG)	200°C (400°F)	1.60 mm (0.063")	JDG	JDE
	4.1 bar (60 PSIG)	200°C (400°F)	2.39 mm (0.094")	JEG	JEE
	4.1 bar (60 PSIG)	370°C (700°F)	1.40 mm (0.055")	JFG	JFE
Series K non bleed type	6.9 bar (100 PSIG)	200°C (400°F)	—	KOE	KOE
	2.8 bar (40 PSIG)	200°C (400°F)	—	KOG	—

SELECT ELECTRIC SWITCH MECHANISM & ENCLOSURE

Switch Description ①	Max. liquid temp. °C (°F) ②	Contacts	Cont. per enclosure	All models with material of construction code 1								All models with material of construction codes 2 and 4							
				NEMA 4X cast aluminium			NEMA 7/9 cast iron	BASEEFA cast iron		CENELEC cast iron		NEMA 4X cast aluminium			NEMA 7/9 cast iron	BASEEFA cast iron		CENELEC cast iron	
				1" NPT	M 20 x 1.5	PG 16	1" NPT	M20 x 1.5	3/4" NPT	M20 x 1.5	3/4" NPT	1" NPT	M 20 x 1.5	PG 16	1" NPT	M20 x 1.5	3/4" NPT	M20 x 1.5	3/4" NPT
Series A – Mercury switch	290°C (550°F)	SPDT	1 2 3	AAA	A2A	A3A	AKD	AK8	AU8	AK7	AU7	AAB	A2B	A3B	AKM	AK6	AU6	AK5	AU5
				ABA	A4A	A5A	ALD	AL8	AV8	AL7	AV7	ABB	A4B	A5B	ALM	AL6	AV6	AL5	AV5
Series 3 – Mercury switch with beaded leads	400°C (750°F)	SPDT	1 2 3	3AA	32A	33A	3KD	3K8	3U8	3K7	3U7	3AB	32B	33B	3KM	3K6	3U6	3K5	3U5
				3BA	34A	35A	3LD	3L8	3V8	3L7	3V7	3BB	34B	35B	3LM	3L6	3V6	3L5	3V5
Series B – Snap switch	120°C (250°F)	SPDT	1 2 3	BAA	B2A	B3A	BKD	BK8	BU8	BK7	BU7	BAB	B2B	B3B	BKM	BK6	BU6	BK5	BU5
				BBA	B4A	B5A	BLD	BL8	BV8	BL7	BV7	BBB	B4B	B5B	BLM	BL6	BV6	BL5	BV5
Series C – Snap switch	230°C (450°F)	SPDT	1 2 3	CAA	C2A	C3A	CKD	CK8	CU8	CK7	CU7	CAB	C2B	C3B	CKM	CK6	CU6	CK5	CU5
				CBA	C4A	C5A	CLD	CL8	CV8	CL7	CV7	CBB	C4B	C5B	CLM	CL6	CV6	CL5	CV5
Series D – Snap switch for DC current applications	120°C (250°F)	SPDT	1 2 3	DAB	D2B	D3B	DKM	DK6	DU6	DK5	DU5	DAB	D2B	D3B	DKM	DK6	DU6	DK5	DU5
				DBB	D4B	D5B	DLM	DL6	DV6	DL5	DV5	DBB	D4B	D5B	DLM	DL6	DV6	DL5	DV5
Series E – Vibration resistant mercury switch	290°C (550°F)	SPDT	1 2 3	EAA	E2A	E3A	EKD	EK8	EU8	EK7	EU7	EAB	E2B	E3B	EKM	EK6	EU6	EK5	EU5
				EBA	E4A	E5A	ELD	EL8	EV8	EL7	EV7	EBB	E4B	E5B	ELM	EL6	EV6	EL5	EV5
Series 2 – Vibr. resistant mercury switch with beaded leads	400°C (750°F)	SPDT	1 2 3	2AA	22A	23A	2KD	2K8	2U8	2K7	2U7	2AB	22B	23B	2KM	2K6	2U6	2K5	2U5
				2BA	24A	25A	2LD	2L8	2V8	2L7	2V7	2BB	24B	25B	2LM	2L6	2V6	2L5	2V5
Series F – Snap switch hermetically sealed	400°C (750°F)	SPDT	1 2	FAA	FCA	FPA	FKD	FK8	FU8	FK7	FU7	FAB	FCB	FPB	FKM	FK6	FU6	FK5	FU5
				FBA	FFA	FRA	FLD	FL8	FV8	FL7	FV7	FBB	FFB	FRB	FLM	FL6	FV6	FL5	FV5
Series HS – Snap switch hermetically sealed with terminal block	290°C (550°F)	SPDT	1	HM2	H7A	H6A	HS3	HB1	HB2	HB3	HB4	HM2	H7A	H6A	HS3	HB1	HB2	HB3	HB4
				DPDT	1	HM6	H7C	H6C	HS7	HB5	HB6	HB7	HB8	HM6	H7C	H6C	HS7	HB5	HB6
Series U – Snap switch	120°C (250°F)	SPDT	1 2 3	UAA	U2A	U3A	UKD	UK8	UU8	UK7	UU7	UAB	U2B	U3B	UKM	UK6	UU6	UK5	UU5
				UBA	U4A	U5A	ULD	UL8	UV8	UL7	UV7	UBB	U4B	U5B	ULM	UL6	UV6	UL5	UV5
Series W – Snap switch hermetically sealed	230°C (450°F)	SPDT	1 2 3	WAA	W2A	W3A	WKD	WK8	WU8	WK7	WU7	WAB	W2B	W3B	WKM	WK6	WU6	WK5	WU5
				WBA	W4A	W5A	WLD	WL8	WV8	WL7	WV7	WBB	W4B	W5B	WLM	WL6	WV6	WL5	WV5
Series X – Snap switch hermetically sealed	230°C (450°F)	SPDT	1 2 3	XAA	X2A	X3A	XKD	XK8	XU8	XK7	XU7	XAB	X2B	X3B	XKM	XK6	XU6	XK5	XU5
				XBA	X4A	X5A	XLD	XL8	XV8	XL7	XV7	XBB	X4B	X5B	XLM	XL6	XV6	XL5	XV5
		DPDT	1 2	XCA	X6A	X7A	XMD	X68	X78	X67	X77	XCB	X6B	X7B	XMM	X66	X76	X65	X75
				XDB	X8B	X9B	XNM	XN6	XX6	XD5	XW5	XDB	X8B	X9B	XNM	XN6	XX6	XD5	XW5
				XEB	X1B	X2B	XOM	XO6	XY6	XO5	XY5	XEB	X1B	X2B	XOM	XO6	XY6	XO5	XY5

① Housing heater available in NEMA 4X and 7/9 enclosures. Drain available in NEMA 7/9 enclosures. Consult factory for standard part number.
 ② Temperatures based on 38°C (100°F) ambient.

SEALED CAGE MODEL DIMENSIONAL SPECIFICATIONS IN MM (INCHES)

– Only A75 Model –

Rotation clearance	Ⓛ
NEMA 4X (IP 65)	109 (4.29)
NEMA 7/9	100 (3.94)
BASEEFA & CENELEC	110 (4.33)
Pneumatic K (NEMA 3R)	130 (5.12)
Pneumatic J (NEMA 3R)	110 (4.33)

All housings rotatable 360°

Allow 200 mm (7.87") overhead clearance for cover removal.

Conduit connections	Ⓚ
Electrical switches NEMA 4X (IP 65)	1" NPT, PG 16 or M20 x 1.5 entries (2 entries - one plugged)
NEMA 7/9 BASEEFA & CENELEC	1" NPT-F entry M20 x 1.5 or 3/4" NPT-F entry
Pneumatic switches K Series (Nema 3R) J Series (Nema 3R)	1/4" NPT-F (two entries) 1/4" NPT-F (one entry)

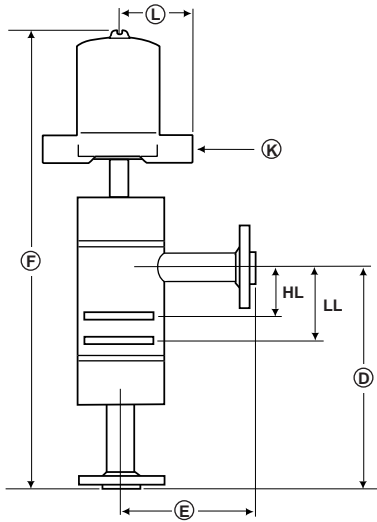

Flanged
upper side/bottom
CENELEC housing

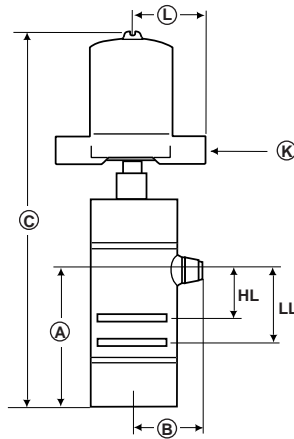

Threaded & socket weld
upper side/bottom
CENELEC housing

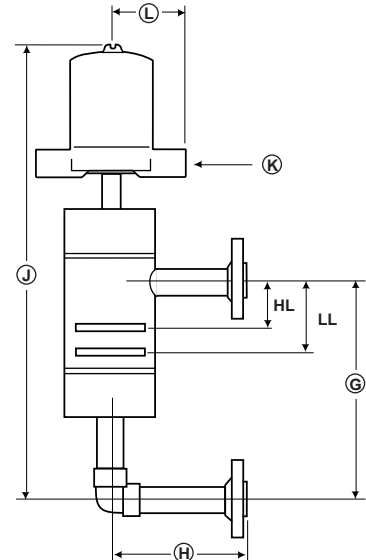

Flanged
side/side
CENELEC housing

– All models except A75 –

Rotation clearance	Ⓛ
NEMA 4X (IP 65)	109 (4.29)
NEMA 7/9	100 (3.94)
BASEEFA & CENELEC	110 (4.33)
Pneumatic K (NEMA 3R)	130 (5.12)
Pneumatic J (NEMA 3R)	110 (4.33)

All housings rotatable 360°.

Allow 200 mm (7.87") over head clearance for cover removal.

Conduit connections	Ⓚ
Electrical switches NEMA 4X (IP 65)	1" NPT, PG 16 or M20 x 1.5 entries (2 entries - one plugged)
NEMA 7/9 BASEEFA & CENELEC	1" NPT-F entry M20 x 1.5 or 3/4" NPT-F entry
Pneumatic switches K Series (Nema 3R) J Series (Nema 3R)	1/4" NPT-F (two entries) 1/4" NPT-F (one entry)

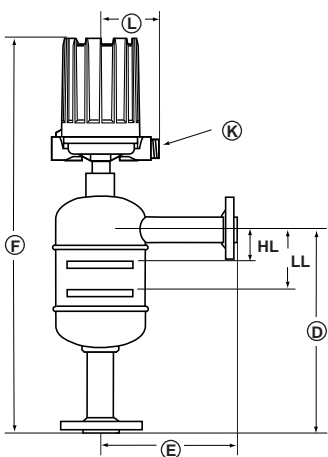

Flanged
upper side/bottom
NEMA 4X housing

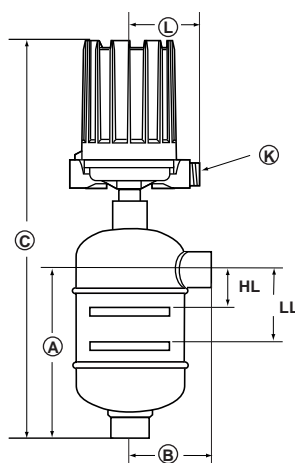

Threaded & socket weld
upper side/bottom
NEMA 4X housing

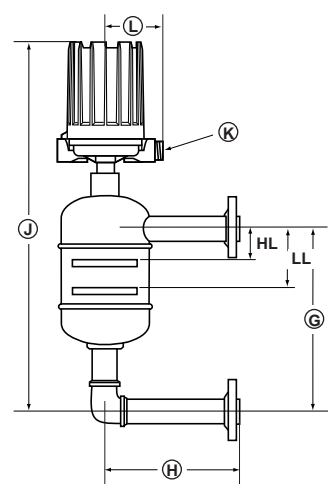

Flanged
side/side
NEMA 4X housing

Carbon steel and Stainless steel chambers with 1" and NW 25 (DIN) connections.

mm Part n° code	1" NPT & socket weld			1" or NW 25 Flanged upper side / bottom			1" or NW 25 Flanged side / side		
	A	B	C (max)	D	E	F (max)	G	H	J (max)
A75	222	82	605	356	185	738	356	185	738
B75	222	95	579	356	200	713	356	200	713
C75	222	95	579	356	200	713	356	200	713
G75	242	109	609	356	215	723	356	215	723
J75	242	109	609	356	215	723	356	215	723
P75*	222	82	567	356	185	701	356	185	701
O75*	222	70	561	356	165	695	356	165	695

inches Part n° code	1" NPT & socket weld			1" or NW 25 Flanged upper side / bottom			1" or NW 25 Flanged side / side		
	A	B	C (max)	D	E	F (max)	G	H	J (max)
A75	8.74	3.23	23.80	14	7.28	29.05	14	7.28	29.05
B75	8.74	3.74	22.79	14	7.87	28.07	14	7.87	28.07
C75	8.74	3.74	22.79	14	7.87	28.07	14	7.87	28.07
G75	9.53	4.29	23.97	14	8.46	28.46	14	8.46	28.46
J75	9.53	4.29	23.97	14	8.46	28.46	14	8.46	28.46
P75*	8.74	3.23	22.32	14	7.28	27.60	14	7.28	27.60
O75*	8.74	2.75	22.08	14	6.50	27.36	14	6.50	27.36

* 316/316L stainless steel only

Carbon steel and Stainless steel chambers with 1 1/2" and NW 40 (DIN) connections.

mm Part n° code	1 1/2" NPT			1 1/2" socket weld			1 1/2" or NW 40 Flanged upper side / bottom			1 1/2" or NW 40 Flanged side / side		
	A	B	C (max)	A	B	C (max)	D	E	F (max)	G	H	J (max)
A75	222	84	605	222	93	605	356	200	738	356	200	738
B75	217	98	584	225	108	592	356	215	723	356	215	723
C75	217	98	584	225	108	592	356	215	723	356	215	723
G75	236	114	613	243	122	620	356	230	733	356	230	733
J75	236	114	613	243	122	620	356	230	733	356	230	733
P75*	217	84	573	224	93	580	356	200	712	356	200	712

inches Part n° code	1 1/2" NPT			1 1/2" socket weld			1 1/2" or NW 40 Flanged upper side / bottom			1 1/2" or NW 40 Flanged side / side		
	A	B	C (max)	A	B	C (max)	D	E	F (max)	G	H	J (max)
A75	8.74	3.30	23.80	8.74	3.66	23.80	14	7.87	29.05	14	7.87	29.05
B75	8.56	3.88	23.00	8.84	4.25	23.30	14	8.46	28.46	14	8.46	28.46
C75	8.56	3.88	23.00	8.84	4.25	23.30	14	8.46	28.46	14	8.46	28.46
G75	9.29	4.49	24.13	9.56	4.80	24.40	14	9.05	28.85	14	9.05	28.85
J75	9.29	4.49	24.13	9.56	4.80	24.40	14	9.05	28.85	14	9.05	28.85
P75*	8.56	3.30	22.56	8.84	3.66	22.83	14	7.87	28.03	14	7.87	28.03

* 316/316L stainless steel only

Carbon steel and Stainless steel chambers with 2" and NW 50 (DIN) connections.

mm Part n° code	2" NPT			2" socket weld			2" or NW 50 Flanged upper side / bottom			2" or NW 50 Flanged side / side		
	A	B	C (max)	A	B	C (max)	D	E	F (max)	G	H	J (max)
A75	222	84	605	222	101	605	356	200	738	356	200	738
B75	211	98	584	228	115	601	356	220	729	356	220	729
C75	211	98	584	228	115	601	356	220	729	356	220	729
G75	231	115	614	248	132	631	356	235	739	356	235	739
J75	231	115	614	248	132	631	356	235	739	356	235	739
P75*	211	84	576	228	101	593	356	200	721	356	200	721

inches Part n° code	2" NPT			2" socket weld			2" or NW 50 Flanged upper side / bottom			2" or NW 50 Flanged side / side		
	A	B	C (max)	A	B	C (max)	D	E	F (max)	G	H	J (max)
A75	8.74	3.31	23.80	8.74	3.97	23.80	14	7.87	29.05	14	7.87	29.05
B75	8.33	3.88	23.00	9.00	4.55	23.66	14	8.66	28.70	14	8.66	28.70
C75	8.33	3.88	23.00	9.00	4.55	23.66	14	8.66	28.70	14	8.66	28.70
G75	9.11	4.53	24.17	9.78	5.20	24.84	14	9.25	29.09	14	9.25	29.09
J75	9.11	4.53	24.17	9.78	5.20	24.84	14	9.25	29.09	14	9.25	29.09
P75*	8.33	3.31	22.67	9.00	3.97	23.34	14	7.87	28.38	14	7.87	28.38

* 316/316L stainless steel only

ACTUATING LEVELS

Actuating levels shown are for single switch units at minimum specific gravity only. Levels will change for multistage units. Consult factory for these units.

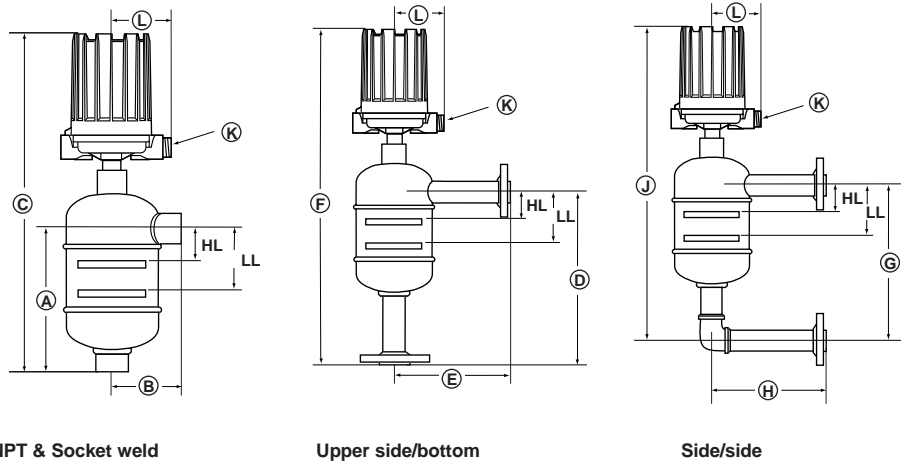

Material code 1 (for minimum specific gravity)

1" and NW 25 (DIN) connections NPT, flanged side - side or side - bottom

1 1/2" and NW 40 (DIN) connections NPT, flanged side - side or side - bottom

2" and NW 50 (DIN) connections NPT, flanged side - side or side - bottom

Part n° code	mm (inches)	
	HL	LL
A75	24 (0.94)	47 (1.85)
B75	76 (3.00)	92 (3.62)
C75	76 (3.00)	93 (3.66)
G75	64 (2.50)	81 (3.18)
J75	79 (3.12)	97 (3.81)

Part n° code	mm (inches)	
	HL	LL
A75	24 (0.94)	47 (1.85)
B75	59 (2.31)	75 (2.94)
C75	61 (2.38)	78 (3.07)
G75	46 (1.81)	63 (2.48)
J75	62 (2.44)	80 (3.14)

Part n° code	mm (inches)	
	HL	LL
A75	24 (0.94)	47 (1.85)
B75	47 (1.88)	63 (2.48)
C75	49 (1.94)	66 (2.59)
G75	38 (1.50)	55 (2.16)
J75	54 (2.12)	72 (2.83)

Material code 2 and 4 (for minimum specific gravity)

1" and NW 25 (DIN) connections NPT, flanged side - side or side - bottom

1 1/2" and NW 40 (DIN) connections NPT, flanged side - side or side - bottom

2" and NW 50 (DIN) connections NPT, flanged side - side or side - bottom

Part n° code	mm (inches)	
	HL	LL
A75	25 (0.98)	52 (2.05)
B75	76 (3.00)	96 (3.77)
C75	70 (2.77)	93 (3.63)
G75	64 (2.50)	84 (3.30)
O75	75 (2.94)	103 (4.05)
P75	65 (2.56)	89 (3.50)

Part n° code	mm (inches)	
	HL	LL
A75	25 (0.98)	52 (2.05)
B75	59 (2.31)	79 (3.11)
C75	53 (2.08)	76 (3.00)
G75	46 (1.88)	66 (2.60)
P75	48 (1.88)	72 (2.83)

Part n° code	mm (inches)	
	HL	LL
A75	25 (0.98)	52 (2.05)
B75	47 (1.88)	67 (2.63)
C75	41 (1.61)	64 (2.51)
G75	38 (1.50)	58 (2.28)
P75	36 (1.41)	60 (2.36)



QUALITY ASSURANCE - ISO 9001

THE QUALITY ASSURANCE SYSTEM IN PLACE AT MAGNETROL GUARANTEES THE HIGHEST LEVEL OF QUALITY DURING THE DESIGN, THE CONSTRUCTION AND THE SERVICE OF CONTROLS. OUR QUALITY ASSURANCE SYSTEM IS APPROVED AND CERTIFIED TO ISO 9001 AND OUR TOTAL COMPANY IS COMMITTED TO PROVIDING FULL CUSTOMER SATISFACTION BOTH IN QUALITY PRODUCTS AND QUALITY SERVICE.

PRODUCT WARRANTY

ALL MAGNETROL MECHANICAL LEVEL CONTROLS ARE WARRANTED FREE OF DEFECTS IN MATERIALS AND WORKMANSHIP FOR FIVE FULL YEARS FROM THE DATE OF ORIGINAL FACTORY SHIPMENT.

IF RETURNED WITHIN THE WARRANTY PERIOD; AND, UPON FACTORY INSPECTION OF THE CONTROL, THE CAUSE OF THE CLAIM IS DETERMINED TO BE COVERED UNDER THE WARRANTY; THEN, MAGNETROL INTERNATIONAL WILL REPAIR OR REPLACE THE CONTROL AT NO COST TO THE PURCHASER (OR OWNER) OTHER THAN TRANSPORTATION.

MAGNETROL SHALL NOT BE LIABLE FOR MISAPPLICATION, LABOR CLAIMS, DIRECT OR CONSEQUENTIAL DAMAGE OR EXPENSE ARISING FROM THE INSTALLATION OR USE OF THE EQUIPMENT. THERE ARE NO OTHER WARRANTIES EXPRESSED OR IMPLIED, EXCEPT, SPECIAL WRITTEN WARRANTIES COVERING SOME MAGNETROL PRODUCTS.



UNDER RESERVE OF MODIFICATIONS

BELGIUM	Heikensstraat 6, 9240 Zele Tel. (052) 45.11.11	Fax (052) 45.09.93
DEUTSCHLAND	Schloßstraße 76, D-51429 Bergisch Gladbach-Bensberg Tel. (02204) 9536-0	Fax (02204) 9536-53
FRANCE	11, Rue A. Einstein, Espace Descartes, 77420 Champs-sur-Marne adresse postale: 77436 Marne-la-Vallée Cédex 2 Tel. (0) 164.68.58.28	Fax. (0) 164.68.58.27
ITALIA	Via Arese 12, I-20159 Milano Tel. (02) 607.22.98 (R.A.)	Fax (02) 668.66.52
UNITED KINGDOM	Unit 1 Regent Business Centre Jubilee Road Burgess Hill West Sussex RH 15 9TL Tel. (01444) 871313	Fax (01444) 871317
INDIA	B4/115 Safdurjung Enclave, New Delhi 110 029 Tel. 91 (11) 6186211	Fax 91 (11) 6186418

OUR NEAREST REPRESENTATIVE

BULLETIN N°: BE 46-115.12
EFFECTIVE: JANUARY 1996
SUPERSEDES: January 1994