



Product sheet

971 SmartRadar LTi storage tank measurement

The advanced radar for tank level gauging with custody transfer accuracy

Benefits

- Highly performing non contact measuring principle
- Highest reliability and long term stability
- Optimized for easy service and diagnostics
- Easy integration via field proven communications
- Modular design to simplify operations
- Complies to all major standards

The new 971 SmartRadar LTi is the most advanced version within the Enraf SmartRadar family. It completes the broad range of Enraf level gauges to provide fit for purpose solutions for all thinkable level gauging applications in the area of liquid bulk storage.

The 971 SmartRadar LTi uses state of the art radar technology, supported by Enraf's extensive tank gauging know how, to provide the performance required for accurate level measurement on larger bulk storage tanks. The SmartRadar LTi complies with all major tank gauging standards from API, ISO etc.

The new Smart Echo Analysis signal processing results in highly reliable measurement, even under the most difficult conditions. The SmartRadar LTi is capable of providing radar performance with the long term reliability and stability, required from the industry standards as set by the Enraf servo instruments.

It's modular design grants the efficient use of the SmartRadar LTi together with other members of the Enraf level gauging family, using identical option boards and antenna's.

For the standard communication, Enraf's own robust and field proven Bi-Phase Mark communication protocol is selected as being the market standard in field communication in tank terminals. Advanced communication and service features even further optimize the operation of this device compared to older generations.

Direct interfacing to third party systems can be realized using standardized communication protocols suitable for tank gauging applications, such as HART® and Modbus.



Measuring specifications

Measuring range	: 0 m to 40 m (0 ft to 131 ft)
Instrument accuracy	: ± 1 mm (0.04") ¹⁾
Measuring resolution	: 0.1 mm (0.004")

Principles

Measuring principle	: FM Synthesized Pulse Reflectometer
Signal processing	: Advanced Digital Signal Processing (ADSP)
Operating frequency	: X-band (9.5 GHz to 10.6 GHz) (FCC: 9.5 GHz to 10.5 GHz)

Mechanical

Dimensions	: See drawing opposite
Weight	: 10 kg excluding antenna and separator
Cable entries	: 3 pcs 3/4" NPT (Pending on regulations Ex-d cable glands must be used)

Environmental

Ambient temperature	: -40 °C to +60 °C (-40 °F to +140 °F)
Storage temperature	: -50 °C to +85 °C (-58 °F to +185 °F)
Protection class	: IP 67 according to EN 60529 (NEMA 4)
Safety	: Explosion-proof <ul style="list-style-type: none"> - ATEX II 1/2 G EEx d IIB T4 or EEx de IIB T4 or EEx d [ia/ib] IIB T4 or EEx de [ia/ib] IIB T4 - Class I, Division 1, Groups B, C and D, acc. to ANSI / NFPA 70 (FM, USA)
Over voltage protection	: II
Pollution degree	: I

Materials

Instrument unit housing	: Aluminum alloy EN AC-ALSi7Mg0,3 EN1706, mat. No. 3.2371
Instrument unit finish	: Chromitized according to MIL-C-5541C
O-rings: Wetted	: Viton
Non-wetted	: Buna NBR70

Electrical

Power supply	: 110 V to 240 Vac, autoselect (+10 % to -20 %) 45 / 65 Hz or 24 Vdc to 64 Vdc, autoselect (+10 % to -20 %)
Power rating	: Basic 10 VA, 25 VA max. with options

Transmission

Type	: Serial, ASCII coded, Bi-Phase Mark modulated (BPM)
Lightning protection	: Full galvanic separation via isolation transformers
Protocol	: Standard Enraf fieldbus (GPU protocol)
Common mode rejection	: >150 dB
Cabling	: Two conductors, twisted pair, $R_{max} = 200 \Omega / \text{line}$, $C_{max} = 1 \mu\text{F}$, max. Length 10 km

Options

i.s. output channel	: For Tank Side Indicator (TSI)
Communication boards	
Output	: - Standard Modbus via RS-232C or RS-485 - 4-20 mA with digital communication based on HART® protocol, accuracy analog level signal ± 0.1 %, full scale
Input	: - Spot RTD, VITO probes for average temperature and/or water bottom measurement - HART® devices
Alarm relay output	: 1x SPDT, galvanically isolated, $V_{max} = 50$ Vac or 75 Vdc, $I_{max} = 3$ A
Infrared connector	: Serial communication with Portable Enraf Terminal (PET)

HART® is a trademark of the HART Communications Foundation.

¹⁾ Under reference conditions

Identification code

Pos 1 Application															
U	General purpose														
A	Including individual test report														
Pos 2 Data transmission															
E	Enraf Bi-phase mark protocol (standard)														
I	i.s. output for Tank Side Indicator (TSI) and Enraf Bi-phase Mark (BPM) protocol														
H	HART and 4-20 mA output and Enraf BPM protocol														
K	HART and 4-20 mA output, i.s. output for TSI and Enraf Bi-phase Mark (BPM) protocol														
R	RS-232C GPU protocol														
S	RS-485 GPU protocol														
T	RS-232C GPU protocol and i.s. output for TSI														
U	RS-485 GPU protocol and i.s. output for TSI														
V	RS-232C standard Modbus														
W	RS-485 standard Modbus														
X	RS-232C standard Modbus and i.s. output for TSI														
Y	RS-485 standard Modbus and i.s. output for TSI														
Pos 3 Pressure version															
A	Atmospheric														
M	Medium pressure 6 bar / 600 kPa (87 psi)														
Pos 4 I/O options															
B	Spot temperature Pt100														
C	VITO temperature and/or water probe														
J	VITO temperature and/or water probe + HART device(s)														
U	Spot temperature Pt100 + HART device(s)														
Y	Spot temperature Pt 100 + VITO temperature and/or water probe + HART device(s)														
Z	None														
Pos 5, 6, 7 Instrument designation															
9	7	1	SmartRadar LTi												
Pos 8 Safety approvals															
A	ATEX Europe														
P	FM/FCC USA														
For other approvals please contact your nearest Enraf office															
Pos 9 Alarms															
W	With programmable SPDT level alarm relay														
Z	None														
Pos 10 Mains supply															
B	110 Vac - 240 Vac (+10% / -20%), 45 / 65 Hz														
D	24 Vdc - 64 Vdc (+10% / -20%)														
Pos 11, 12, 13 SmartRadar antenna's															
F	0	8	8" PAT, free space												
S	0	6	6" PAT, still pipe												
S	0	8	8" PAT, still pipe												
S	1	0	10" PAT, still pipe												
S	1	2	12" PAT, still pipe												
Pos 14, 15 Stem length															
0	5	5 cm													
3	0	30 cm													
5	0	50 cm													
8	0	80 cm													
Pos 16 IR connection															
W	With IR-connector														
Z	Without IR-connector														
Typical identification code															
U	E	A	Z	9	7	1	A	Z	B	S	0	8	3	0	W
Your identification code															
U				9	7	1									

For SmartRadar antennas see also Product sheet "SmartRadar antennas"

Outputs

- Standard : Enraf Bi-Phase Mark communication
 Optional : • RS-232C or RS-485 (GPU or Modbus)
 • HART® & 4-20 mA level output

For communication to indicators and systems

- Intrinsically-safe channel for the Tank Side Indicator (TSI)
 • Relay for hard wire level alarm

Inputs

- HART® devices
 • Spot temperature element
 • VITO probes for average temperature and/or water bottom measurement

Configuration

- Enraf service tool for use with a PC or laptop using Enraf Bi-Phase Mark communication, RS-232C, RS-485, HART® interface
 • Portable Enraf Terminal (PET) using infra-red connector

Display (optional)

- Field Display & Interface (FDI) and Control Panel Indicator (CPI) using Enraf Bi-Phase Mark communication
 • Tank Side Indicator (TSI) using intrinsically-safe connection

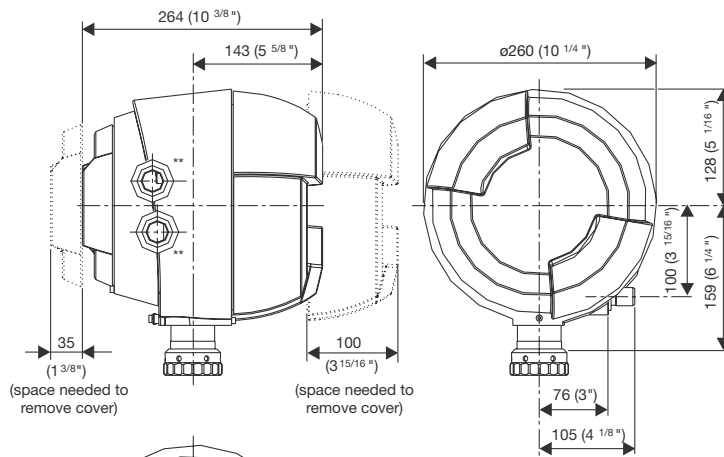

SmartRadar LTI



Field interface



Entis system

* Cable Entry 3/4" NPT, Ex-i (1x)
 ** Cable Entry 3/4" NPT (2x)

We at Enraf are committed to excellence.

Enraf B.V.

Delftechpark 39, 2628 XJ Delft
 P.O. Box 812, 2600 AV Delft, The Netherlands
 Tel.: +31 (0)15 2701 100, Fax: +31 (0)15 2701 111
 Email: info@enraf.nl, http://www.enraf.com

China: Enraf B.V. (Shanghai Rep. Office)

18G, International Shipping & Finance Center
 720 Pudong Avenue, Shanghai 200120
 Tel.: +86 21 50367000, Fax: +86 21 50367111

France: ENRAF S.a.r.l.

ZAC les Beaudottes, 15 rue Paul Langevin
 93270 SEVRAN
 Tel.: +33 (0)1 49 36 20 80, Fax: +33 (0)1 43 85 26 48

Germany: Enraf GmbH

Obere Dammstrasse 10, 42653 Solingen
 Postfach 101023, 42648 Solingen
 Tel.: +49 (0)212 58 750, Fax: +49 (0)212 58 7549

Russia: Enraf B.V. (Moscow Rep. Office)

21, Dostoevskogo street
 127 473 Moscow
 Tel. / Fax: +7 (0)95 788 0713,
 Tel. / Fax: +7 (0)95 788 0691

Singapore: Enraf Singapore Pte Ltd

Lam Soon Industrial Building
 63 Hillview Avenue, # 07- 04, Singapore 669569
 Tel.: +65 676 94 857, Fax: +65 683 67 496

United Kingdom: Enraf Ltd.

Unit D2, Melville Court, Spilsby Road
 Harold Hill, Romford, Essex Rm3 8SB
 Tel.: +44 (0)1708 346 333, Fax: +44 (0)1708 370 670

USA: ENRAF Inc.

4333 West Sam Houston Parkway North, Suite 190
 Houston, TX 77043
 Tel.: +1 832 467 3422, Fax: +1 832 467 3441

Information in this publication is subject to change without notice.

© Enraf is a registered trademark © Enraf B.V. The Netherlands



WE THINK TANK