



Product sheet

Servo Gauge 854ATG

A compact, intelligent and reliable Advanced Tank Gauge

Benefits

Simple Commissioning

Easy to install

Proven reliability

Multi-functional

The series 854ATG servo gauge is a very reliable, versatile and accurate automatic tank gauge with a minimum of moving parts.

The present instrument range is designed for the measurement of all kind of liquids in any type of storage tank. Operating pressures up to 40 bar (4 MPa / 600 psig) and a very wide product temperature range can be handled.

Simple configuration and diagnostics are possible via the Portable Enraf Terminal (PET) connected through a safe infra-red coupling or via Enraf configuration software. The instruments are Explosion proof and certified by the authorities for Weights & Measures.

The multi-functional instrument is modularly constructed. The option slot for additional features allows the connection of temperature measuring elements for spot- and average product temperature, as well as for product temperature profiles.

Other options are full integration in a Hybrid Inventory Management System (HIMS), analog level output, density measurement, product interface, water/product interface measurement and Modbus output via RS-232C or RS-485 for direct connection to other host control systems.

As tank gauging has evolved, the servo level gauge has become an industrial standard all over the world. A true test of its quality is the dependability and low warranty record that the ATG has maintained for many years.



Measuring specifications	
Measuring range	: Standard 27 m (88 ft) Optional 37 m (121 ft) 35 m (115 ft) (with measuring wire up to 150 m (492 ft))
Measuring accuracy level	: $\leq \pm 0.4$ mm (± 0.016 ") ¹⁾
Measuring accuracy interface	: $\leq \pm 2$ mm (± 0.08 ") ²⁾
Measuring accuracy density	: $\leq \pm 3$ kg/m ³ (± 0.19 lb/ft ³) ³⁾
Measuring accuracy temp.	: ± 0.1 °C (± 0.18 °F) ^{1) 4)}
Sensitivity	: ± 0.1 mm (± 0.004 ") ¹⁾
Repeatability	: ± 0.1 mm (± 0.004 ") ¹⁾
Wave integration time	: Programmable, three setpoints, between 0.5 s and 10 s
Mechanical	
Flange	: See 'Identification code', Pos 9, 10
Dimensions	: See back page
Weight	: Medium pressure version 16 kg (35 lb) Chemical version 21 kg (46 lb) High pressure version 26kg (57 lb)
Cable entries	: 4 pcs 3/4" NPT threaded
Environmental	
Operating pressure	: M and C version : up to 6 bar / 0.6 MPa (90 psi) H version : up to 40 bar / 4 MPa (600 psi) (up to 25 bar / 2.5 MPa in acc. to PED)
Ambient temperature	: -40 °C to +65 °C (-40 °F to +149 °F)
Protection class	: IP 65 according to EN 60529 (NEMA 4)
Safety	: Explosion proof - II 1/2 G EEx d IIB T6 or EEx de IIB T6 or EEx d [ia/ib] IIB T6 or EEx de [ia/ib] IIB T6 according to ATEX - Class I, Division 1, Groups B, C and D, in acc. to ANSI / NFPA 70 (FM, USA)
Materials	
Housing servo comp. & cover	: All types cast aluminum Int. reg. AA A356 EN1706 AC-AISI7Mg0,3
Drum compartment	: M version cast aluminum Int. reg. AA A356 EN1706 AC-AISI7Mg0,3 C & H version stainless steel ASTM A351, CF-8M, G-X6 CrNiMo 18 10 (1.4408)
Finish aluminum parts	: Chromatinized according to MIL-C-5541C
Measuring drum, drum shaft	: Stainless steel (1.4401) EN10088 \equiv AISI 316
Measuring wire	: See 'Identification code', Pos 12
Magnet cap	: Stainless steel (1.3953)
O-rings	: Drum cover Silicone / FEP (others NBR 70)
Electrical	
Power supply	: 110/130/220 V (+10% to -20%) and 230 V ($\pm 15\%$), optional 65 V (+10% to -20%), also suitable for 240 V (+10% to -20%)
Frequency variations	: 50 Hz to 60 Hz ($\pm 10\%$)
Power rating	: 25 VA, I _{max} = 2 A
Transmission	
Type	: Serial, ASCII coded, Bi-Phase Mark modulated (BPM)
Isolating voltage	: > 1,500 V
Lightning protection	: Full galvanic separation via isolating transformers
Protocol	: Standard Enraf fieldbus (GPU protocol)
Common mode rejection	: > 150 dB
Cabling	: Two conductors, twisted pair, R _{max} = 200 Ω / line, C _{max} = 1 μ F
Transmission to Portable Enraf Terminal (PET)	: Infra-red, serial
Options	
Alarm relay outputs	: 2x SPDT, galvanically isolated, V _{max} = 50 Vac or 75 Vdc, I _{max} = 3 A
Density measurement	: See 'Identification code', Pos 15 (with density displacer)
Analog level output	: 4 - 20 mA (accuracy $\pm 0.1\%$ full scale)
Input boards	: Spot RTD, VITO probes for average temperature and/or water measurement, HART® devices
Data transmission	: Standard Modbus via RS-232C or RS-485 i.s. output for Tank Side Indicator (TSI)
Cable entries	: Adapters available to fit other sizes cable glands

HART® is a trademark of the HART Communications Foundation.

¹⁾ Under reference conditions

²⁾ Difference product density 100 kg/m³ (6.25 lb/ft³)

³⁾ (optional) with a density displacer and calibrated for density measurement

⁴⁾ With VITO temperature probe

Pos 1 Application									
U General purpose					X W&M certified				
Pos 2 Data transmission									
E Enraf Bi-phase mark protocol (standard)									
I i.s. Output for Tank Side Indicator (TSI) and Enraf Bi-Phase Mark (BPM) protocol									
R RS-232C GPU protocol (only when Pos 4 = B, C, G, J, M, U or Z)									
S RS-485 GPU protocol (only when Pos 4 = B, C, G, J, M, U or Z)									
V RS-232C standard Modbus (only when Pos 4 = B, C, G, J, M, U or Z)									
W RS-485 standard Modbus (only when Pos 4 = B, C, G, J, M, U or Z)									
Pos 3 Display									
A With display									
Pos 4 I/O options									
B Spot temperature Pt100					V Analog level output				
C VITO temperature and/or water probe					W Analog level output + VITO temperature and/or water probe				
G Average temperature MIR interface + HART device(s)					X Analog level output + VITO temperature probe				
J VITO temp. and/or water probe + HART device(s)					Y Analog level output + spot temperature Pt 100 + VITO temp. and/or water probe + HART device(s)				
M Average temperature MIR interface					Z None				
N Average temp. MIR interface + Analog level output									
U Spot temperature Pt100 + HART device(s)									
Pos 5, 6, 7 Instrument designation									
8 5 4 Servo gauge ATG									
Pos 8 Pressure version									
C Up to 6 bar 0.6 MPa (90 psi) if Pos 9, 10 = 11, 12 or 13									
M Up to 6 bar 0.6 MPa (90 psi) if Pos 9, 10 = 21 or 22									
H Up to 40 bar 4 MPa (600 psi) if Pos 9, 10 = 51, 52, 53 or 54 (25 bar according PED)									
Pos 9, 10 Drum compartment & flange									
		mat. *)	flange	acc. to	finish	compatible with	acc. to		
1	1	ss	2" 150 lbs rf	ANSI B16.5	turning, Ra = 3.2 - 12.5 µm	DN50, PN20 rf	ISO 7005-1		
1	2	ss	NW50 ND6 form D	DIN 2501 DIN 2526	turning, Rz = max. 40 µm	DN50, PN6 rf	ISO 7005-1		
1	3	ss	2" 150 lbs ff	ANSI B16.5	turning, Ra = 3.2 - 12.5 µm	DN50, PN20 ff	ISO 7005-1		
2	1	Al	2" 150 lbs ff	ANSI B16.5	turning, Ra = 3.2 - 12.5 µm	DN50, PN20 ff	ISO 7005-1		
2	2	Al	NW50 ND6 form B	DIN 2501 DIN 2526	turning, Rz = 40 - 160 µm	DN50, PN6 ff	ISO 7005-1		
5	1	ss	2" 300 lbs rf	ANSI B16.5	turning, Ra = 3.2 - 12.5 µm	DN50, PN50 rf	ISO 7005-1		
5	2	ss	2" 300 lbs rf	ANSI B16.5	turning, Ra = 3.2 - 6.3 µm	DN50, PN50 rf	ISO 7005-1		
5	3	ss	NW50 ND40 form C	DIN 2501 DIN 2526	turning, Rz = 40 - 160 µm	DN50, PN40 rf	ISO 7005-1		
5	4	ss	NW50 ND40 form E	DIN 2501 DIN 2526	turning, Rz = max. 16 µm	DN50, PN40 rf	ISO 7005-1	*) see also technical specifications	
Pos 11 Safety approvals									
A ATEX Europe					For other approvals please contact your nearest Enraf office				
F FM USA									
Pos 12 Measuring range & wire material									
2 27 m (88 ft) AISI 316					K 37 m (121 ft) Hasteloy C22				
A 27 m (88 ft) Hasteloy C22					L 37 m (121 ft) Tantalum				
B 27 m (88 ft) Tantalum					M 37 m (121 ft) Invar				
C 27 m (88 ft) Invar					N 37 m (121 ft) Platinum / 20% Iridium				
D 27 m (88 ft) Platinum / 20% Iridium					9 35 m (115 ft) AISI 316 with 150 m (492 ft) wire length				
3 37 m (121 ft) AISI 316									
Pos 13 Purge connection									
* Option not used					L 1/4" BSP entry				
Pos 14 Mains supply									
A 220 V 50/60 Hz					R 130 V 50/60 Hz				
C 110 V 50/60 Hz					S 65 V 50/60 Hz				
K 230 V 50/60 Hz									
Pos 15 Density measurement									
D With servo density measurement					* Option not used				
Pos 16 Alarms									
W With 2 programmable SPDT alarms					Z No alarms				

U E A Z 8 5 4 M 2 1 A 2 * A * Z Typical identification code

A 8 5 4 Your identification code

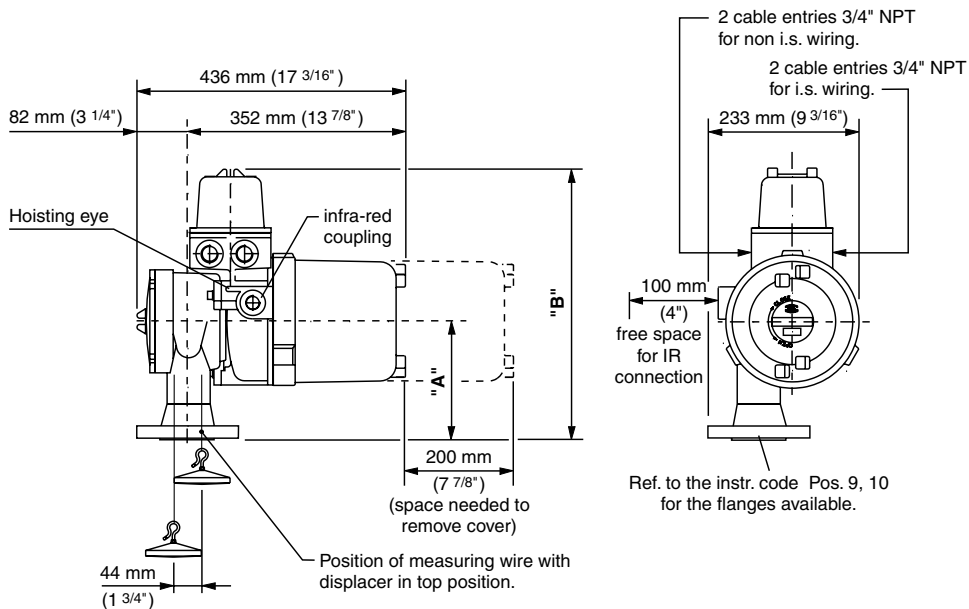

	"A"	"B"
M and C version	184 mm (7 1/4")	427 mm (16 13/16")
H version	206 mm (8 1/8")	449 mm (17 11/16")

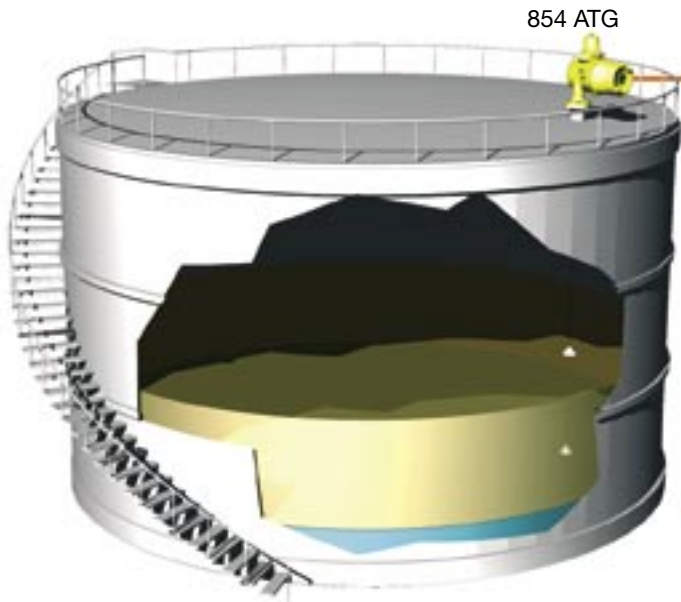

854 ATG

Cable specifications Serial transmission

Number of wires : 1 twisted pair (pref. shielded)
 Resistance : $R_{max} = 200 \Omega / \text{line}$
 Capacitance : $C_{max} = 1 \mu\text{F}$

Outputs

- Modbus
- 4-20 mA for level
- Two relay level alarms
- i.s. Output for Tank Side Indicator
- Digital transmission to
 - indicators
 - systems

Inputs

- HART® devices
- Spot temperature element
- VITO probes for average temp. and/or water bottom measurement



Field interface

Entis system

We at Enraf are committed to excellence.

Enraf B.V.
 Delftechpark 39, 2628 XJ Delft
 P.O. Box 812, 2600 AV Delft, The Netherlands
 Tel.: +31 (0)15 2701 100, Fax: +31 (0)15 2701 111
 Email: info@enraf.nl, http://www.enraf.com

China: Enraf B.V. (Shanghai Rep. Office)
 18G, International Shipping & Finance Center
 720 Pudong Avenue, Shanghai 200120
 Tel.: +86 21 50367000, Fax: +86 21 50367111

France: ENRAF S.a.r.l.
 ZAC les Beaudottes, 15 rue Paul Langevin
 93270 SEVRAN
 Tel.: +33 (0)1 49 36 20 80, Fax: +33 (0)1 43 85 26 48

Germany: Enraf GmbH
 Obere Dammstrasse 10, 42653 Solingen
 Postfach 101023, 42648 Solingen
 Tel.: +49 (0)212 58 750, Fax: +49 (0)212 58 7549

Russia: Enraf B.V. (Moscow Rep. Office)
 21, Dostoevskogo street
 127 473 Moscow
 Tel. / Fax: +7 (0)95 788 0713
 Tel. / Fax: +7 (0)95 788 0691

Singapore: Enraf Pte. Ltd.
 89 Science Park Drive, #03-06 Rutherford
 Singapore Science Park 1, Singapore 118261
 Tel.: +65 676 94 857, Fax: +65 683 67 496

United Kingdom: Enraf Ltd.
 Unit D2, Melville Court, Spilsby Road
 Harold Hill, Romford, Essex RM3 8SB
 Tel.: +44 (0)1708 346 333, Fax: +44 (0)1708 370 670

USA: ENRAF Inc.
 4333 West Sam Houston Parkway North, Suite 190
 Houston, TX 77043
 Tel.: +1 832 467 3422, Fax: +1 832 467 3441

Information in this publication is subject to change without notice.

© Enraf is a registered trademark © Enraf B.V. The Netherlands



WE THINK TANK