

MVS205 Multi-Variable Sensor

The MVS205 Multi-Variable Sensor provides static pressure, differential pressure, and process temperature inputs to a FloBoss™ Flow Manager or to a Remote Operations Controller (ROC). The inputs from a MVS sensor are used in performing orifice flow calculations. The MVS205 operates as a remote unit which communicates via a serial format.

Functionally, the MVS is a sensor device that measures three flow-related variables simultaneously. These variables are continuously available to the FloBoss or ROC unit that polls the MVS. Two versions of the MVS sensor are available: MVS205P with reference accuracy of 0.075% and MVS205E with reference accuracy of 0.10%.

The MVS consists of a transducer and an interface circuit. The transducer, contained in the sensor body, uses capacitance-cell technology to sense differential pressure and piezoresistive technology to sense the static (absolute or gauge) pressure.

The transducer electronics convert the pressure variables directly into a digital format, allowing accurate correction and compensation. The raw temperature is converted by the interface board into digital format. A microprocessor linearizes and corrects the raw pressure signals (from the sensor) using characterization data stored in non-volatile memory.

The interface circuit allows the MVS to connect to and communicate with a ROC or FloBoss using a serial EIA-485 (RS-485) connection. In a Remote MVS, this interface circuit board is enclosed in a explosion-proof electronics head.

An external three or four-wire RTD is used to sense the process temperature. **The RTD sensor is connected directly to the interface circuit board** of the MVS sensor. A separate RTD cable assembly is required for the connection.

FloBoss 407 units may use a remote or integral MVS205 sensor. ROC300-Series controllers must be equipped with a Remote MVS Interface (CMA8H). FloBoss 500-Series units must be equipped with a CR1 to connect with a Remote MVS.

Attached to the bottom of the sensor body is a Coplanar™ flange. This flange, which provides drain/vent valves, allows the MVS to be mounted on a pipestand, on a wall or panel, or on an integral orifice assembly or manifold valve.

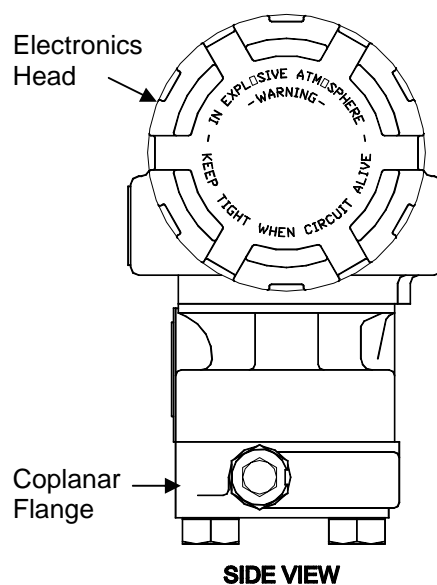
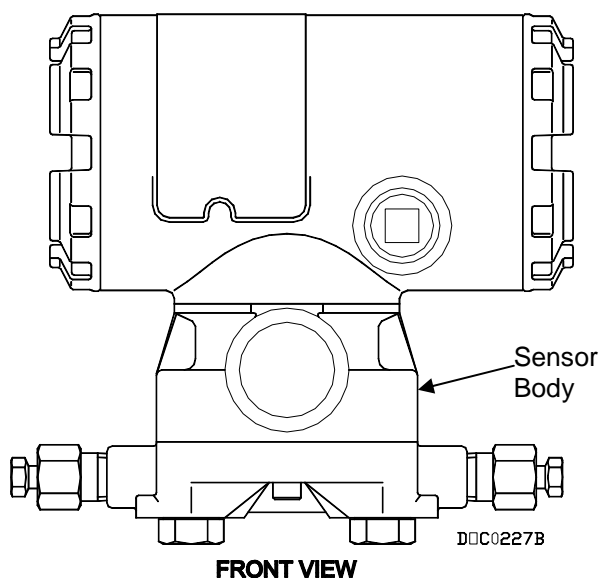

MVS205 Multi-Variable Sensor

Specifications

DIFFERENTIAL PRESSURE INPUT

Range: 0 – 6.22 kPa (0 – 25" H₂O),
0 - 62.2 kPa (0 – 250" H₂O), or
0 – 248.8 kPa (0 – 1000" H₂O).

Reference Accuracy:

±0.075% of span (for MVS205P)
±0.10% of span (for MVS205E).
Includes linearity, hysteresis, and repeatability effects for spans up to 10:1 turndown.

Stability: ±0.1% of upper range limit for 12 months.

STATIC PRESSURE INPUT

Range: Either Absolute or Gauge:
0 - 5516 kPa (0 - 800 psia/psig)
0 – 25,000 kPa (0 - 3626 psia/psig)

Reference Accuracy:

±0.075% of span (for MVS205P)
±0.10% of span (for MVS205E).
Includes linearity, hysteresis, and repeatability effects for spans up to 6:1 turndown.

Stability: ±0.1% of upper range limit for 12 months.

PROCESS TEMPERATURE INPUT

Type: For 3 or 4-wire platinum 100-ohm RTD (conforming to IEC 751 Class B), with $\alpha = 0.00385$.

Range: -40 to 400°C (-40 to 752°F).

Reference Accuracy: ±0.28°C (±0.5°F), exclusive of RTD sensor error. Specification includes linearity, hysteresis, and repeatability effects.

Excitation Current: 200 μ A.

OUTPUT (MVS205 REMOTE ONLY)

RS-485 asynchronous serial communication using Modbus protocol for up to 1220 m (4000 ft) distance.

POWER

30 mA dc maximum at 8 to 30 Vdc, supplied by ROC/FloBoss or Remote MVS Interface.

ENVIRONMENTAL

Operating Temperature: -40 to 75°C (-40 to 167°F).

Storage Temperature: -50 to 85°C (-58 to 185°F).

Operating Humidity: 0 to 99%, non-condensing.

WEIGHT

Including head, 3.0 kg (6.7 lb).

DIMENSIONS

147 mm H by 163 mm W by 84 mm D (5.8 in. H by 6.4 in. W by 3.3 in. D).

CONSTRUCTION

Sensor Body and Coplanar Flange: 316 SST.

Wetted Parts: 316 SST is standard; Hastelloy C (NACE compliant) is available. Wetted O-rings are glass-filled TFE.

Electronics Head (MVS205 Remote): Urethane-painted die-cast aluminum alloy, rated Type 4X.

MOUNTING (MVS205 REMOTE ONLY)

Pipestand: Mounts on 50 mm (2 in.) pipe with U-bolt and optional flange bracket.

Wall/panel: Mounts with optional flange bracket, bolted on 71 mm (2.8 in.) centers.

CONNECTIONS

Conduit: Head has two 1/2-inch NPT connections.

Process: 1/4-18 NPT on 2-1/8 inch centers.

APPROVALS (MVS205 REMOTE ONLY)

Approved by CSA as Models RSE or RSP Series. Product is marked with the following approvals.

CSA Class I, Division 1, Groups C & D, Explosion Proof, C US.¹

CSA Class I, Division 2, Groups A, B, C & D, T5 (T_{Amb}=70°C), T4 T_{Amb}=75°C), C US, with non-incendive output for RTD.²

Approved by the Alberta Boilers Safety Association (approval # 0F0792.2).

1. Note: Installation requires the use of conduit and unarmored cable for RTD connection.

2. Note: When installed in Division 2 areas, the RTD wiring is considered non-incendive. Armored cable without conduit may be used.

FloBoss is a mark of one of the Emerson Process Management companies. The Emerson logo is a trademark and service mark of Emerson Electric Co. All other marks are the property of their respective owners.

The contents of this publication are presented for informational purposes only. While every effort has been made to ensure informational accuracy, they are not to be construed as warranties or guarantees, express or implied, regarding the products or services described herein or their use or applicability. Fisher Controls reserves the right to modify or improve the designs or specifications of such products at any time without notice.

Emerson Process Management

Flow Computer Division

Marshalltown, IA 50158 U.S.A.

Houston, TX 77065 U.S.A.

Pickering, North Yorkshire UK Y018 7JA

