

# THE DANIEL **JUNIORSONIC™** GAS FLOW METER

## IDEAL FOR

- NON-CUSTODY TRANSFER LOCATIONS
- CHECK METERING
- STORAGE MEASUREMENT
- OFFSHORE METERING
- WET GAS APPLICATIONS



**DANIEL®**

FISHER-ROSEMOUNT™



**FEATURES & ADVANTAGES  
OF THE  
DANIEL JUNIORSONIC  
GAS FLOW METER**

- ▶ Dual path redundancy
- ▶ Cost advantage over SeniorSonic
- ▶ No line obstruction
- ▶ No pressure loss
- ▶ Bi-directional measurement
- ▶ Large turn-down ratio
- ▶ Field-proven Mark II Electronics
- ▶ No moving parts
- ▶ Low maintenance
- ▶ Immediate alarm reporting
- ▶ Extensive self diagnostics
- ▶ Fully digital electronics
- ▶ Tolerant of wet or dirty gas

# The Daniel JuniorSonic™ Gas Flow Meter

All of the advantages of ultrasonic gas flow measurement  
in a less expensive, spooled meter body!

## Ultrasonic measurement fundamentals

The Daniel JuniorSonic Gas Flow Meter measures the transit times of ultrasonic waves passing through the flowing gas in a pipeline to determine the average velocity of the gas movement. The measurement paths are angled with respect to the pipe axis. Each path has two transducers which act alternately as a transmitter and receiver for the ultrasonic signal's energy, permitting the upstream and downstream transit times to be measured. Since the path lengths and angles are known, and since the electronic characteristics of the transducer pairs can be measured, the transit time measurements contain all of the information necessary to determine the velocity of the moving gas along the measurement paths.

Since the JuniorSonic Gas Flow Meter utilizes centerline paths, an additional piece of information is needed to determine the average velocity of the moving gas (remember that not all gas is moving at the same velocity). A "flow profile correction factor", sometimes called the Reynold's Number correction factor, is needed to reduce the velocity measured along the paths to the correct average for the cross sectional area. This can be accomplished by either using a fixed value or more accurately by measuring pressure and temperature, and then applying an active correction to the measured transit times. Once the corrected mean velocity is determined, the flowrate is calculated by multiplying the average velocity by the cross sectional area of pipe.

## The path configuration

The JuniorSonic Gas Flow Meter has a unique path configuration. Two paths are configured at right angles to one another in a "bull's-eye" arrangement with each path located 45° from vertical. This dual-path configuration provides a more representative measurement of the entire flow profile than single-path meters. Each path measures a velocity and the average velocity is computed by weighting each path's contribution equally. The placement of the paths at a 45° angle from the vertical insures that the paths will not be susceptible to interference from liquids or debris which may be present at the bottom of the pipeline.

### The bounce!

Unlike the Daniel SeniorSonic Gas Flow Meter, the JuniorSonic design bounces the ultrasonic signal across the meter body. While this method is unacceptable for custody transfer accuracy, it is a convenient method which simplifies construction of the meter and makes the meter less susceptible to interference from pipeline debris. Additionally the longer path length allows the meter to be constructed in smaller sizes than the SeniorSonic and may provide some relief from bulk swirl effects.

### THE MEASURING PRINCIPLE

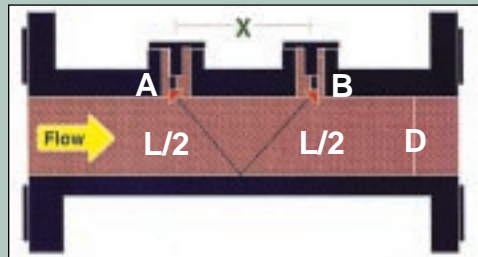

$$t_{AB} = \frac{L}{C + V \frac{X}{L}}$$
$$t_{BA} = \frac{L}{C - V \frac{X}{L}}$$
$$V = \frac{L^2}{2X} \cdot \frac{t_{BA} - t_{AB}}{(t_{AB})(t_{BA})}$$

Actual volume flow rate is:

$$Q = V \cdot \frac{\pi D^2}{4}$$
$$= K \cdot \frac{t_{BA} - t_{AB}}{(t_{AB})(t_{BA})}$$

where:

- $t_{AB}$  = transit time from transducer A to B
- $t_{BA}$  = transit time from transducer B to A
- L = path distance between transducers
- C = velocity of sound in the gas in static condition
- V = mean velocity of the flowing gas
- X = axial distance between transducers
- D = diameter of the meter bore
- K = constant for a specific meter

## Intrinsically Safe Transducers

The UL safety listing is accomplished through a combination of an explosion proof electronics enclosure, and intrinsically safe transducers. The transducers and transducer leads are designed for maximum safety in a Class 1, Division 1 area without a need for further protection.

## Sizing Charts for Daniel JuniorSonic Gas Flow Meter

The JuniorSonic meter is designed to operate with a velocity range from a few feet per second to 100 feet per second.

These two charts translate the 100 feet per second velocity maximum into flowrates, as a function of pressure. Thus, if the flowrate and pressure of a potential measurement location are known, it is very easy to determine if the maximum

velocity is exceeded. Simply locate the pressure and flowrate coordinate on the chart and determine if that point lies beneath the limit shown for the corresponding line size.

### MAXIMUM FLOWRATES Schedule 40, ANSI/ASME B36.10M

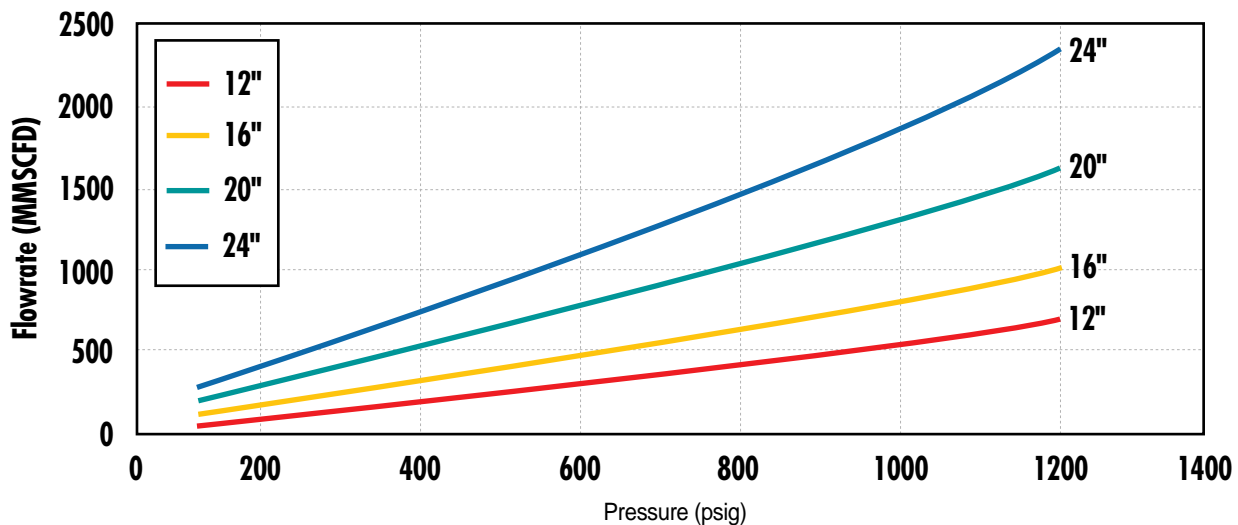
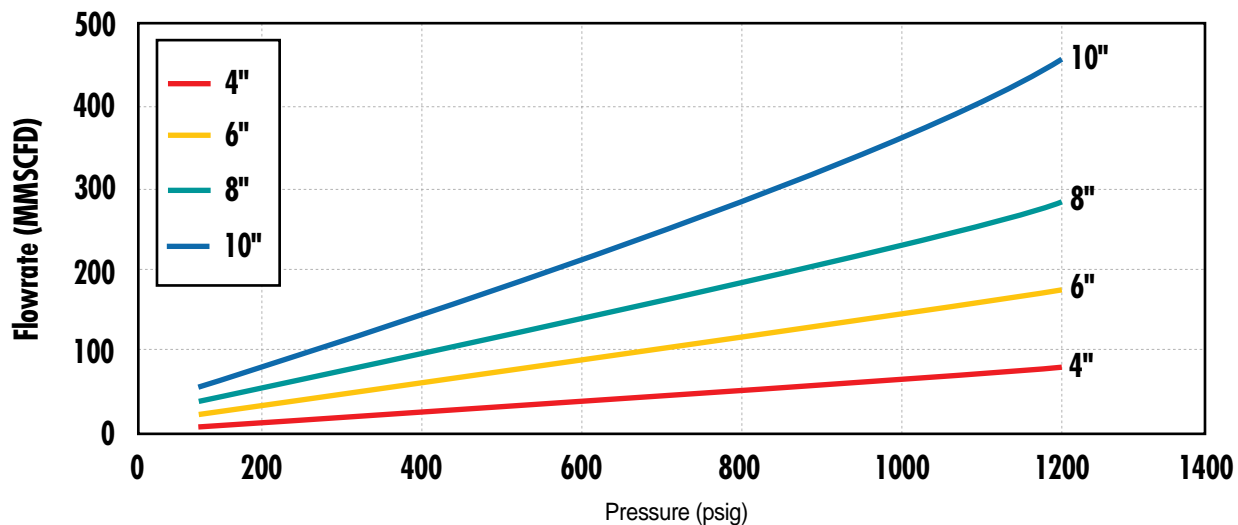

Flowrates in MMSCFD at 100 ft/sec, based on standard compressibility at 70 degrees

# The JuniorSonic Gas Flow Meter with Mark II Electronics

## The Mark II Electronics Module

One of the most significant developments in the history of Daniel's ultrasonic product line is the Mark II Electronics. This unit is a fully digital, Class 1, Division 1 listed module which performs sophisticated waveform processing in real time. Automatic gain control, full diagnostic capability, and a direct serial MODBUS interface make this unit simple to install and use. And, it's the same unit used for the Daniel SeniorSonic and UltraTap Gas Flow Meters, which simplifies maintenance, start-ups, and spare parts stocking considerably!

## The Model 3405 Remote Frequency Interface

The Remote Frequency Interface Module is available when a simpler output format is required. This module reads the Mark II Electronics via the serial communications channel, and is configured to supply the user with a frequency output proportional to flowrate and totalized to match the measured volume. Two analog outputs are also available, along with a data quality indicator (alarm status), a direction indicator, and a serial communications port.

## Meter Configuration

A Daniel JuniorSonic Gas Flow Meter is comprised of the following:

- ▶ Meter body
- ▶ Two or four intrinsically safe, piezoelectric transducers
- ▶ Fully digital, Mark II electronics module
- ▶ Model 3450 Remote Frequency Interface (Optional)



The Mark II electronics module provides the latest in digital processing techniques in a Class 1, Division 1 enclosure.

The JuniorSonic Gas Flow Meter has been engineered for maximum application flexibility and installation ease.

The electronics may be powered by either 110/230 VAC or 24 VDC for convenience. The electronics

module communicates via the standard ASCII modbus protocol through an RS 485 port and all components are either intrinsically safe or mounted into the explosion proof enclosure.

Meter operator communications are via flow computer and temperature/pressure/composition may be used with a flow computer when standard corrected volumes and flowrates are desired.

## Safety First!

The Mark II electronics module is UL listed for Class 1, Division 1 use. This safety rating has been achieved using a combination of intrinsic safety and explosion proof methods. No explosion proof conduit is required and you can be sure that your Daniel product is safe in any classified area!

## Selection of Meter Size

The tables on this page can be used to determine the flow range at reference conditions for meters of 4" to 24". Larger sizes are available. All calculations are based on velocity

ranges from 1, 3, and 100 ft/sec. These recommended ranges may be extended. Contact Daniel to discuss a particular application.

<b>Maximum Flowrates</b> SCHEDULE 40, ANSI/ASME B36.10M								
Pressure (psi)	4"	6"	8"	10"	12"	16"	20"	24"
100.0	6.0	13.5	23.4	36.9	52.4	82.8	130.2	188.3
200.0	11.4	25.8	44.7	70.4	100.0	157.9	248.3	359.2
300.0	16.8	38.2	66.2	104.3	148.1	233.8	367.8	532.0
400.0	22.6	51.2	88.7	139.8	198.4	313.3	492.7	712.6
500.0	28.3	64.2	111.3	175.3	248.9	393.0	618.1	894.0
600.0	34.3	78.0	135.0	212.7	302.0	476.9	750.0	1084.8
700.0	40.6	92.2	159.6	251.5	357.0	563.7	886.8	1282.3
800.0	46.8	106.2	183.9	289.8	411.4	649.6	1021.7	1477.7
900.0	53.4	121.3	210.1	331.0	469.9	742.0	1167.0	1687.8
1000.0	59.9	136.1	235.7	371.3	527.1	832.3	1309.0	1893.3
1100.0	66.6	151.2	261.9	412.7	585.9	925.1	1455.1	2104.5
1200.0	73.5	166.8	288.8	455.1	646.0	1020.0	1604.3	2320.4

Flowrates in MMSCFD at 100 ft/sec, based on standard compressibility at 70 degrees

<b>Minimum Flowrates</b> SCHEDULE 40, ANSI/ASME B36.10M								
Pressure (psi)	4"	6"	8"	10"	12"	16"	20"	24"
100.0	0.2	0.4	0.7	1.1	1.6	2.5	3.9	5.6
200.0	0.3	0.8	1.3	2.1	3.0	4.7	7.5	10.8
300.0	0.5	1.1	2.0	3.1	4.4	7.0	11.0	16.0
400.0	0.7	1.5	2.7	4.2	6.0	9.4	14.8	21.4
500.0	0.8	1.9	3.3	5.3	7.5	11.8	18.5	26.8
600.0	1.0	2.3	4.1	6.4	9.1	14.3	22.5	32.5
700.0	1.2	2.8	4.8	7.5	10.7	16.9	26.6	38.5
800.0	1.4	3.2	5.5	8.7	12.3	19.5	30.7	44.3
900.0	1.6	3.6	6.3	9.9	14.1	22.3	35.0	50.6
1000.0	1.8	4.1	7.1	11.1	15.8	25.0	39.3	56.8
1100.0	2.0	4.5	7.9	12.4	17.6	27.8	43.7	63.1
1200.0	2.2	5.0	8.7	13.7	19.4	30.6	48.1	69.6

Flowrates in MMSCFD at 3 ft/sec, based on standard compressibility at 70 degrees

<b>Extended Minimum Flowrates</b> SCHEDULE 40, ANSI/ASME B36.10M								
Pressure (psi)	4"	6"	8"	10"	12"	16"	20"	24"
100.0	0.1	0.1	0.2	0.4	0.5	0.8	1.3	1.9
200.0	0.1	0.3	0.4	0.7	1.0	1.6	2.5	3.6
300.0	0.2	0.4	0.7	1.0	1.5	2.3	3.7	5.3
400.0	0.2	0.5	0.9	1.4	2.0	3.1	4.9	7.1
500.0	0.3	0.6	1.1	1.8	2.5	3.9	6.2	8.9
600.0	0.3	0.8	1.4	2.1	3.0	4.8	7.5	10.8
700.0	0.4	0.9	1.6	2.5	3.6	5.6	8.9	12.8
800.0	0.5	1.1	1.8	2.9	4.1	6.5	10.2	14.8
900.0	0.5	1.2	2.1	3.3	4.7	7.4	11.7	16.9
1000.0	0.6	1.4	2.4	3.7	5.3	8.3	13.1	18.9
1100.0	0.7	1.5	2.6	4.1	5.9	9.3	14.6	21.0
1200.0	0.7	1.7	2.9	4.6	6.5	10.2	16.0	23.2

Flowrates in MMSCFD at 1 ft/sec, based on standard compressibility at 70 degrees

## Installation



The meter requires only 20 diameters of straight upstream pipe and 5 diameters of straight downstream pipe to achieve an accurate flow measurement. For bi-directional measurements, 20 diameters are required on each side of the meter.

Alternatively, flow conditioning may be used to

insure that the flow profile is well developed for use with an ultrasonic meter. Since all single-path and dual-path meters are sensitive to flow profile effects, if less than recommended straight pipe lengths are used the resulting accuracy of the measurement will likely suffer.

Gas temperature, pressure, and composition should be measured when flow rates and volumes are required at reference conditions (corrected).

## Meter Specifications

### Application:

Pipeline quality natural gas

### Applicable Sizes:

4" - 24" - For larger sizes consult Daniel.

### Gas Temperature Range:

-5 to 185°F

### Pressure Range:

Designs up to ANSI #2500 available

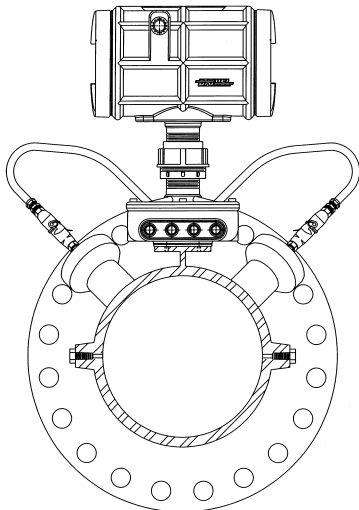

## Recommended Flow Velocity:

Maximum	100 ft/sec
Minimum	3 ft/sec
Extended	1 ft/sec

## Safety Classification:

UL listed for use in Class 1, Group D hazardous locations in both the US and Canada.

CE marked to ATEX Directive (94/9/EC).

Certified to EEx d ia IIB T4 to standards

EN 50014, EN 50018, and EN 50020.

## Safety Method:

Combined explosion proof electronics with intrinsically safe transducers.

## Transducer Options

### Model 3410:

Single-path reflective (one centerline bounce)

### Model 3420:

Dual-path reflective (two centerline bounces)

## Mark II Electronics Unit

### Power:

115/230 VAC +/- 10%, 47 to 63 Hz, 15 W (max)

24 VDC, +/- 10%, 15 W (max)

### Communications:

1 serial port, RS 485 IID 2 wire or RS 232C Tx/D, Rx/D, RTS, and CTS

### Environmental:

Operating Temperature: -40°F to 140°F

Storage Temperature: -40°F to 185°F

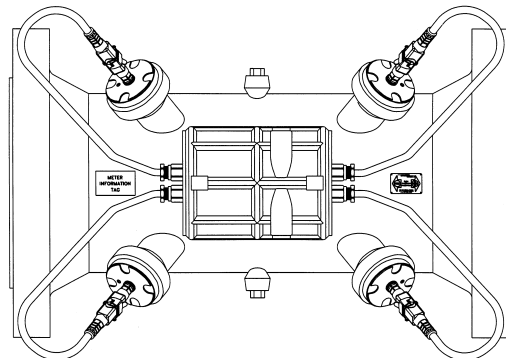

## OPTION SELECTION FOR THE DANIEL JUNIORSONIC GAS FLOW METER

Single Path: 3410  
Dual Path: 3420

100 -

**ELECTRONICS:**

- 1 115/230 VAC/ 3/4" NPT
- 2 115/230 VAC/ 20mm" NPT
- 3 24 VDC/ 3/4" NPT
- 4 24 VDC/ 20mm NPT

**SIZE:**

- 0 4"
- 1 6"
- 2 8"
- 3 10"
- 4 12"
- 5 16"
- 6 20"
- 7 24"
- 8 30"
- 9 36"
- 10 42"

**ANSI CLASS:**

- 3 300
- 5 600
- 6 900
- 7 1500
- 8 2500

**FLANGE TYPE:**

- 1 Raised Face (RF)
- 4 Ring Type Joint (RTJ)

**MATERIAL:**

- 0 Standard Temperature
- 1 Low Temperature

**METER BORE:**

- 0 Special (Specify)
- 3 Schedule 40
- 5 Schedule 80

**EXAMPLE: 3420-3100-451-0-3**

Denotes a 12" Daniel JuniorSonic Gas Flow Meter with ANSI #600 raised face flanges, 24 VDC power input, direct mount transducers and is bored to match schedule 40 internal diameter for use in a standard temperature range (-20°F to 200°F).

LISTED



**DANIEL**

**FISHER-ROSEMOUNT**

*Daniel Industries is a wholly owned subsidiary of Emerson Electric Co., and part of the Fisher-Rosemount group.*



**In addition to the manufacturing plants shown here in Falkirk, Scotland, (above) and Houston, Texas, Daniel also has plants, offices, and representatives around the world to serve customers in over fifty countries.**



Daniel Division Headquarters • Houston, Texas, USA

Telephone: (713) 467-6000 • Fax: (713) 827-3880

Calgary, Alberta, Canada

Telephone: (403) 279-1879 • Fax: (403) 236-1337

Swinton Grange, England

Telephone: +44-1653-695551 • Fax: +44-1653-600425

Singapore

Telephone: +65-777-8211 • Fax: +65-770-8031

**OFFICES AND REPRESENTATIVES WORLDWIDE**

*www.danielind.com*